

IP7 Design Schau

GRUNDLAGEN DER GESTALTUNG 2-D

PUNKT

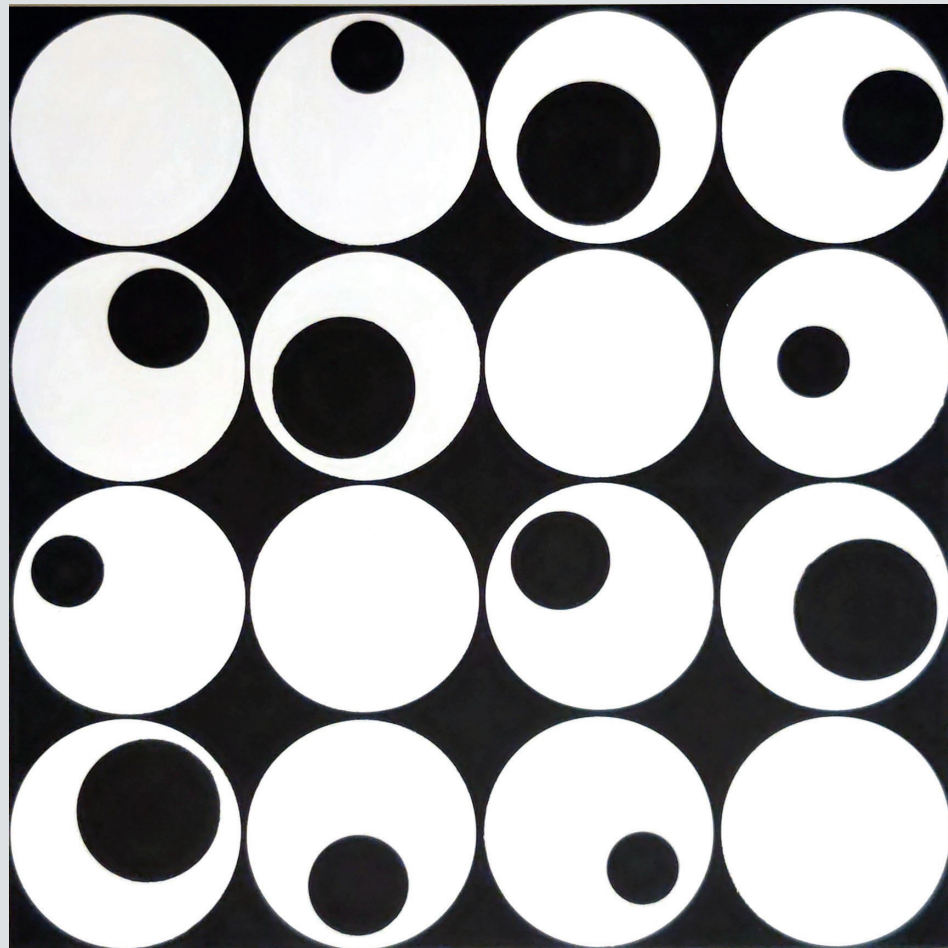

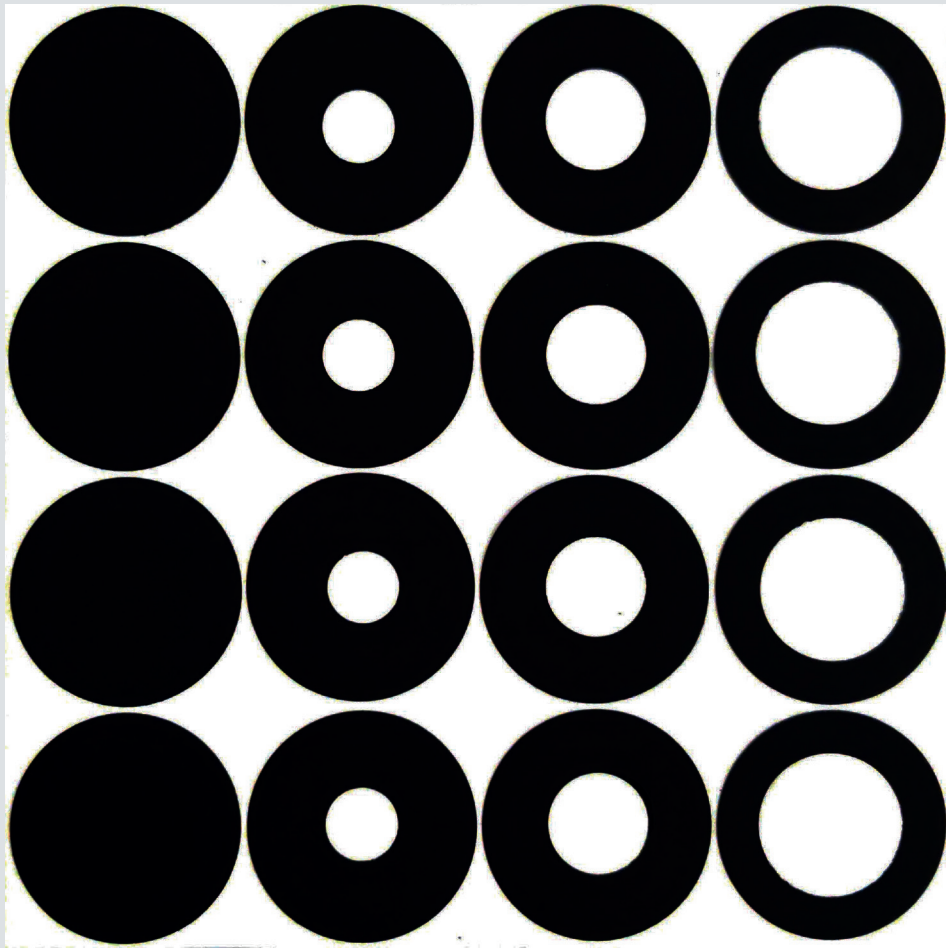
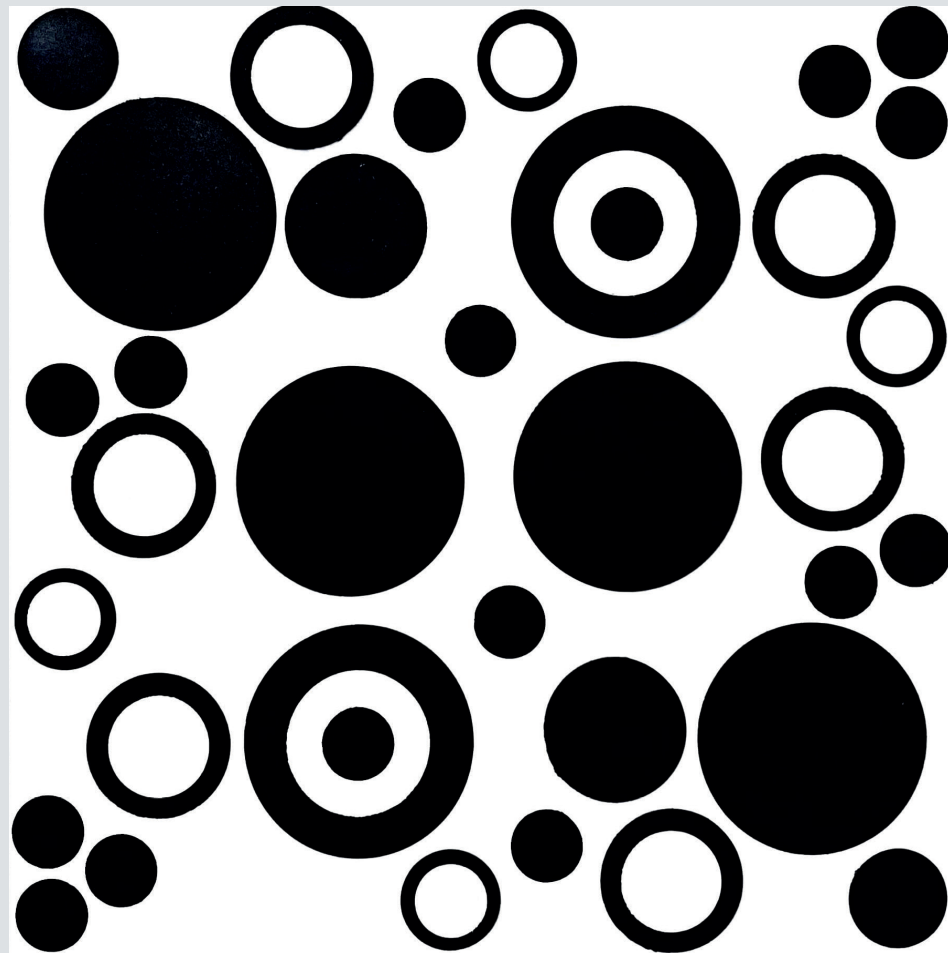
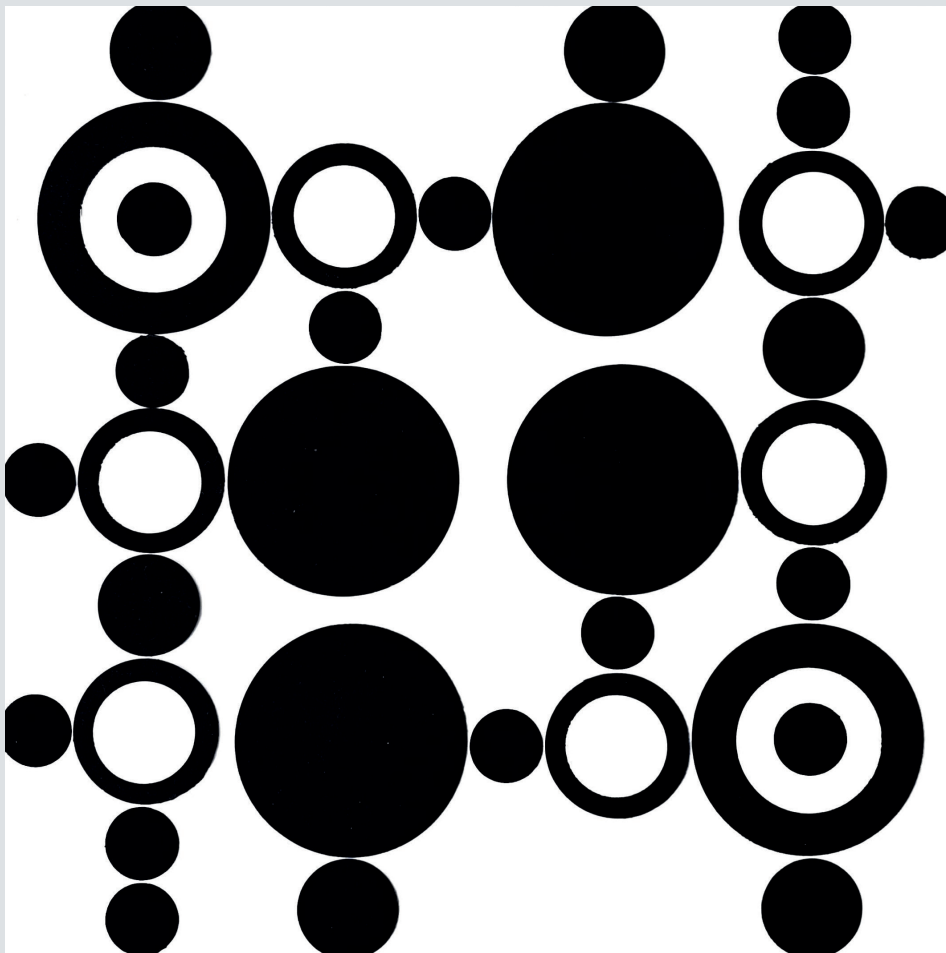

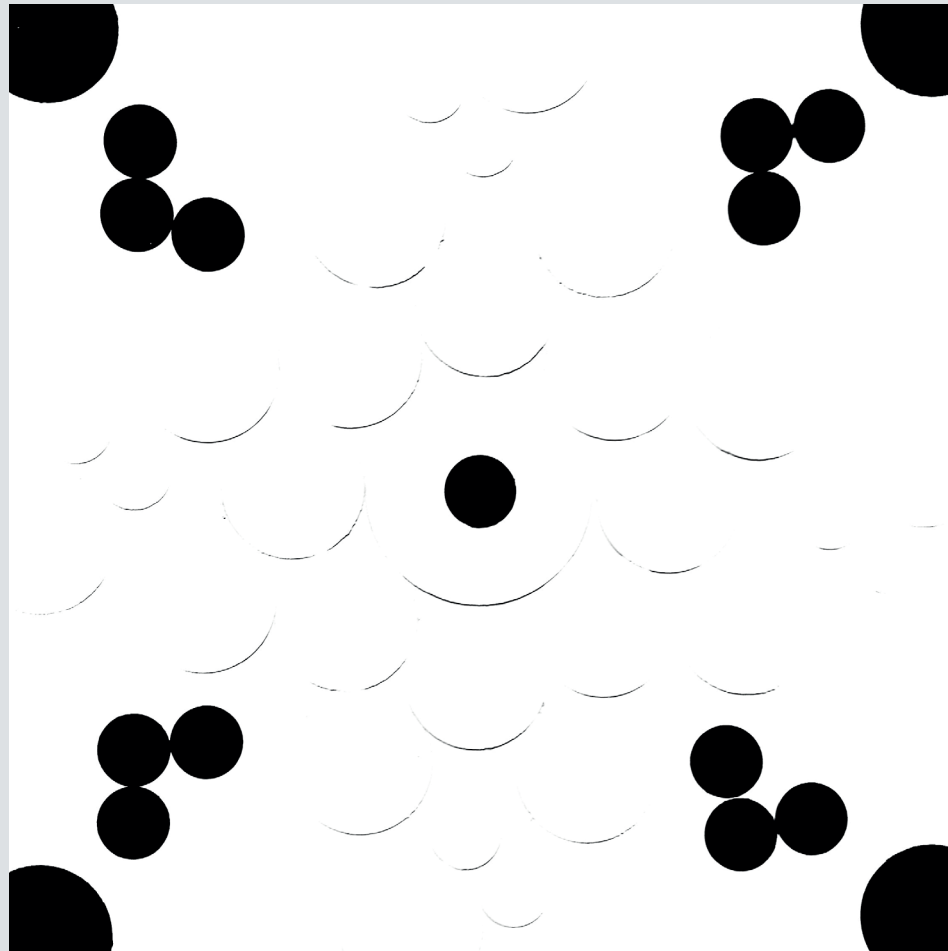
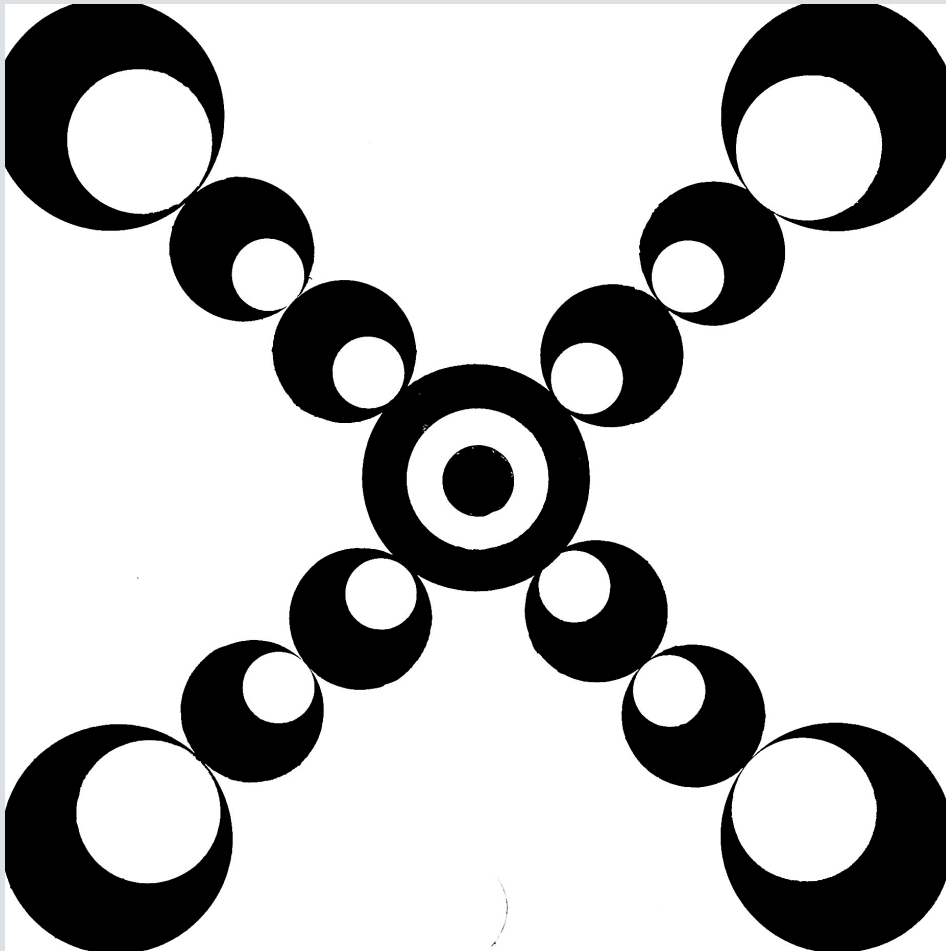

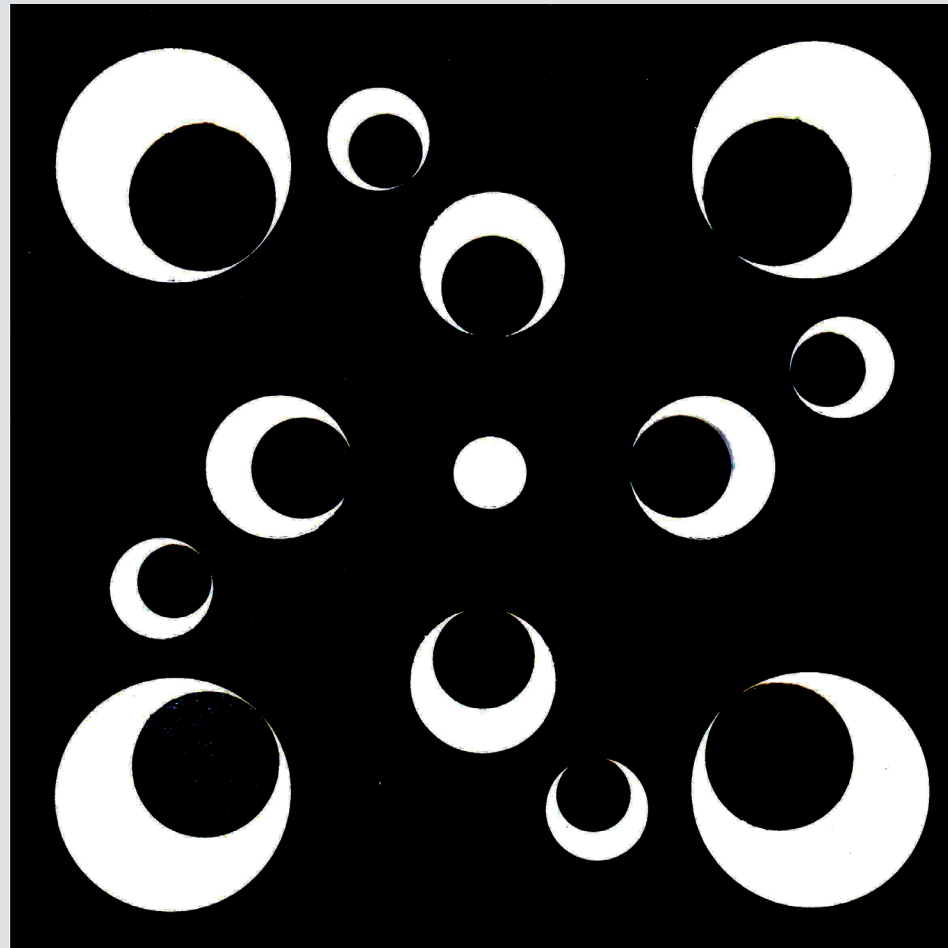
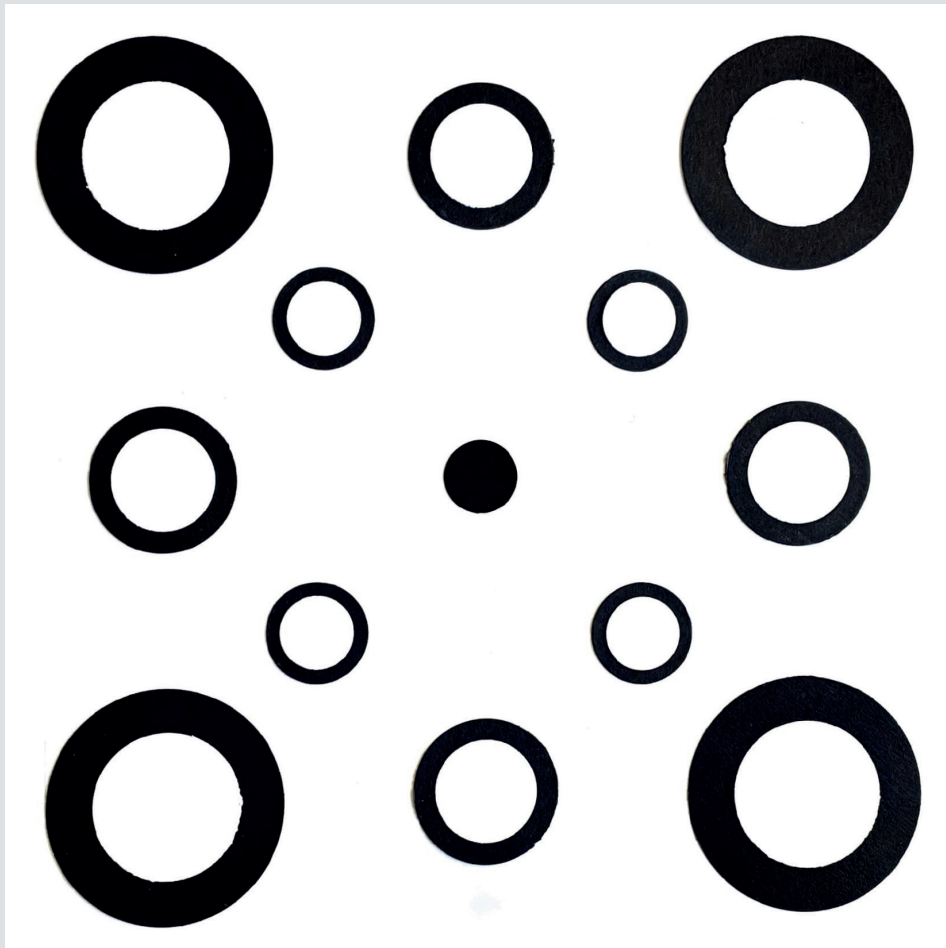

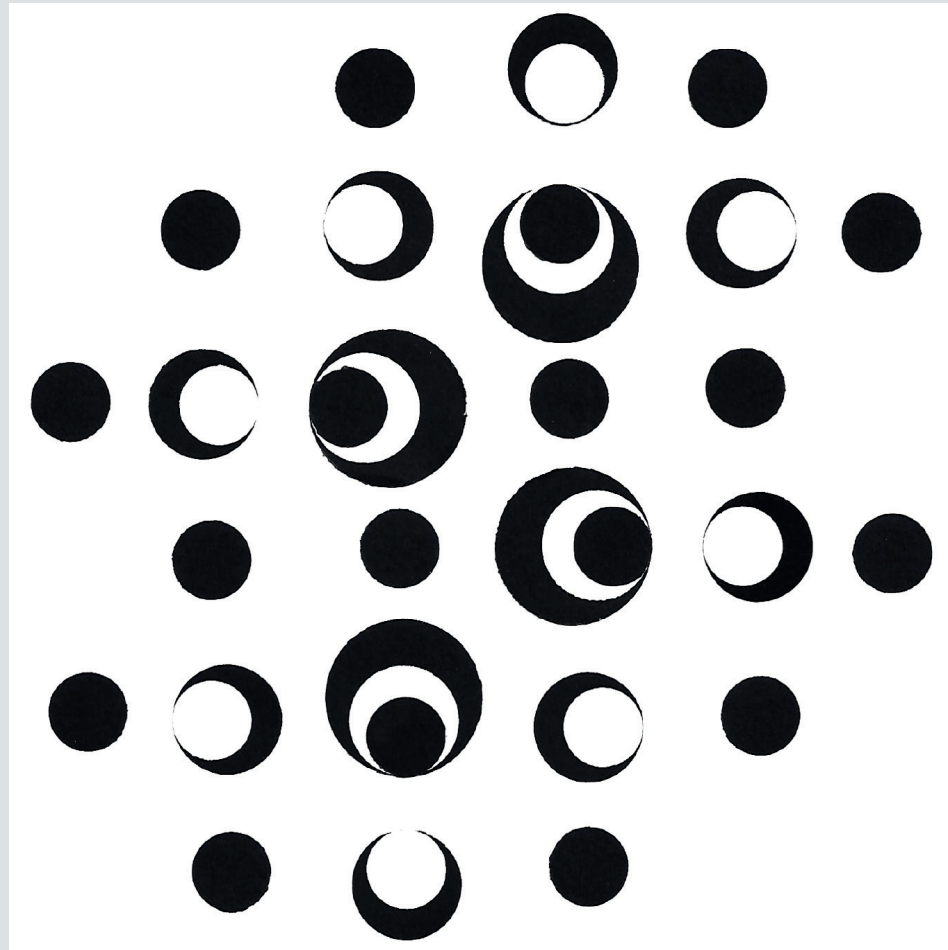
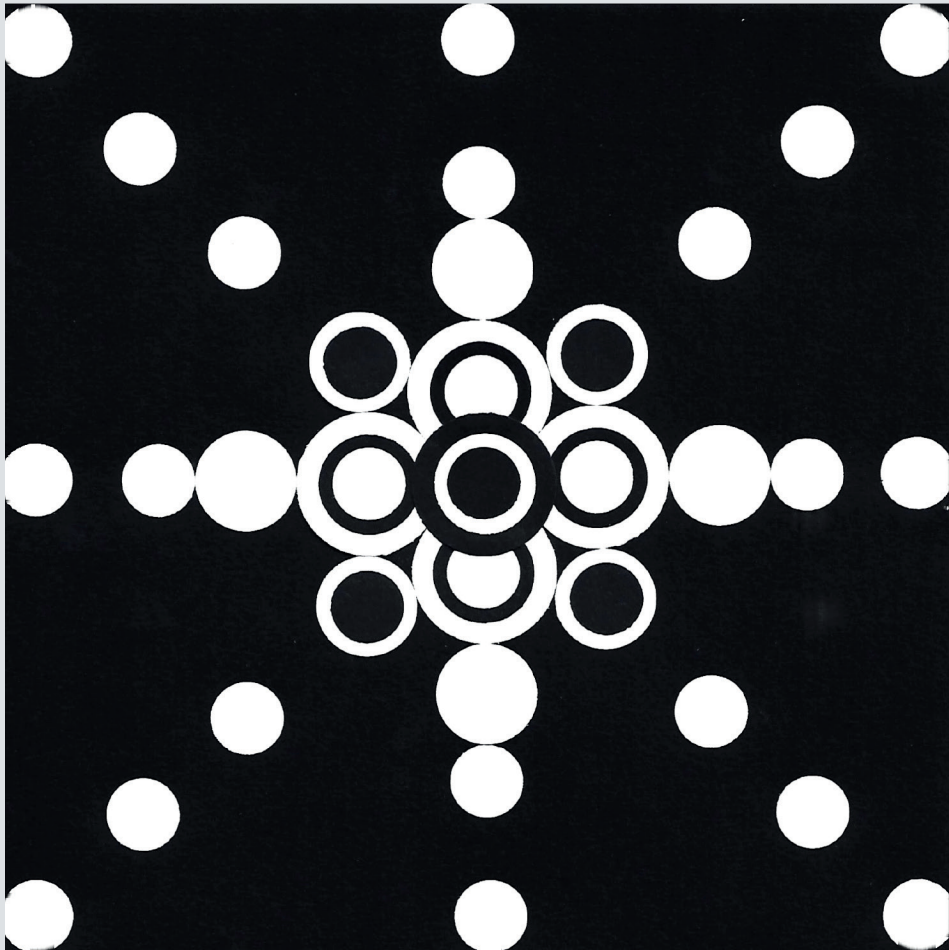

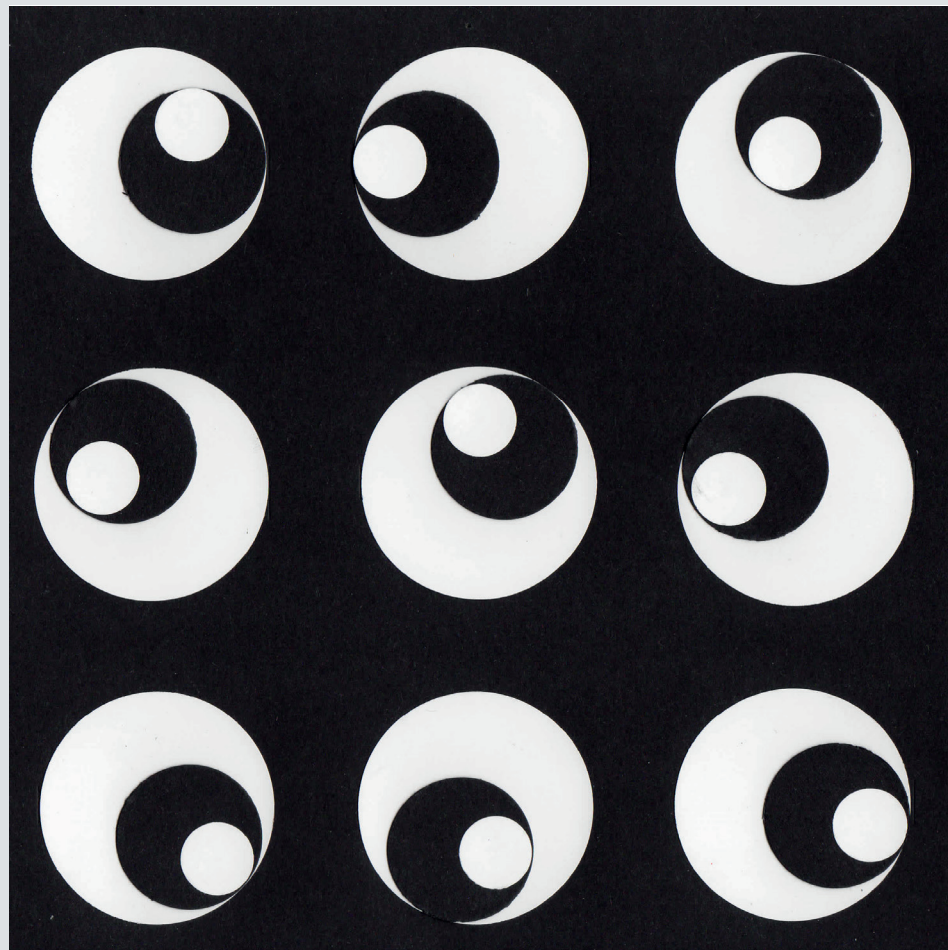
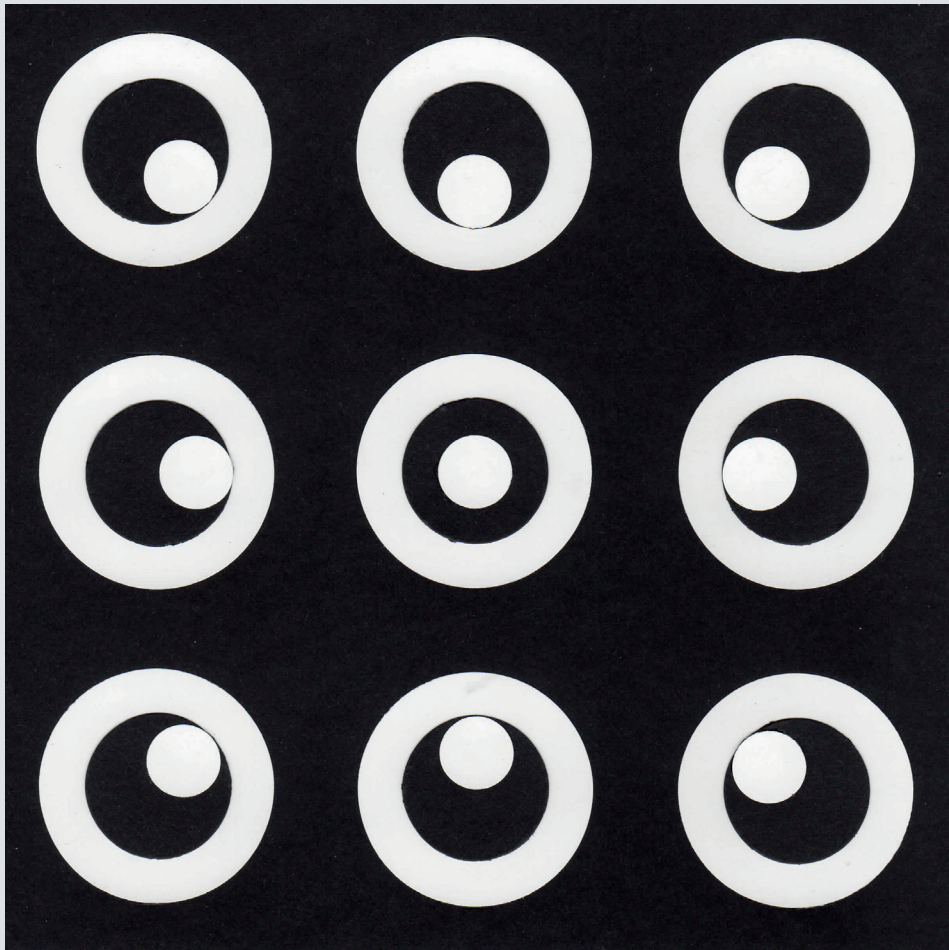

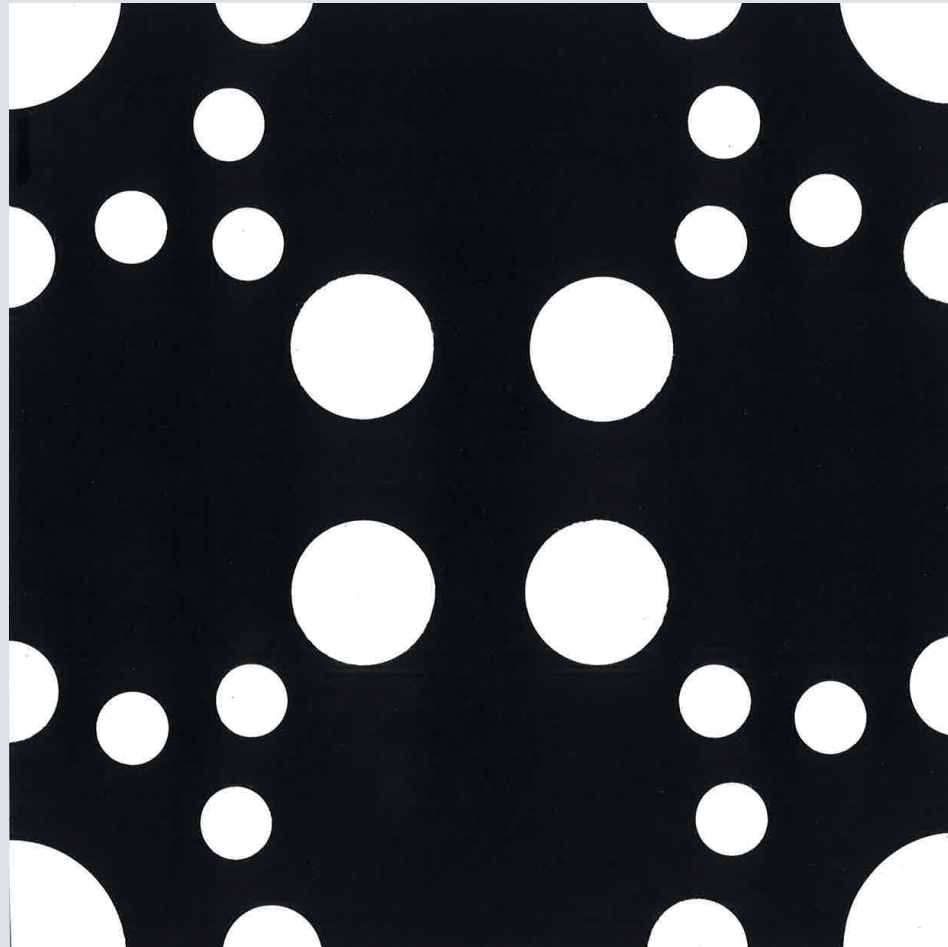
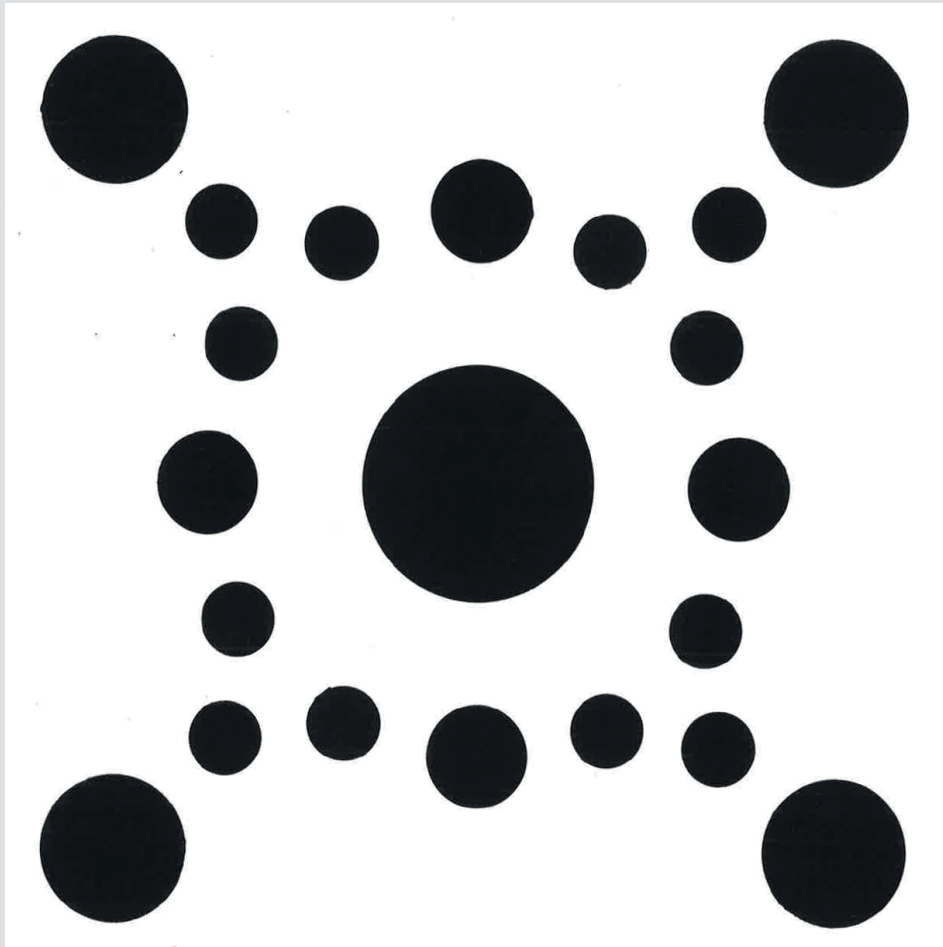

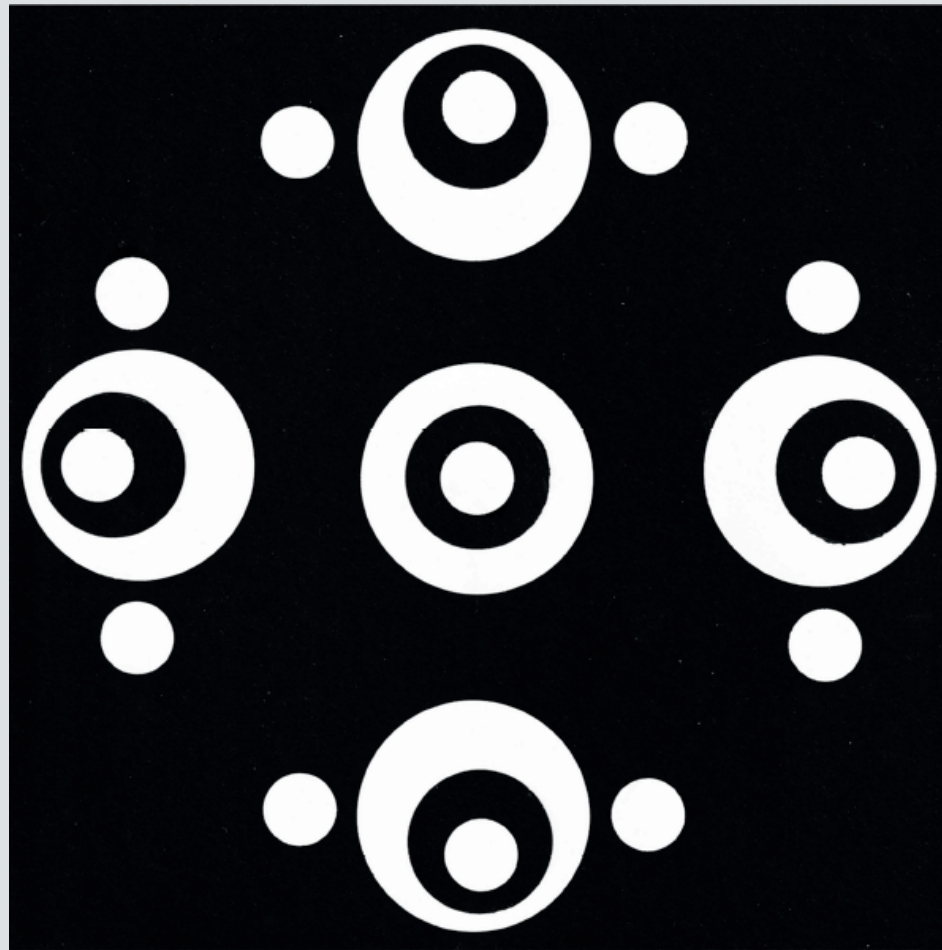
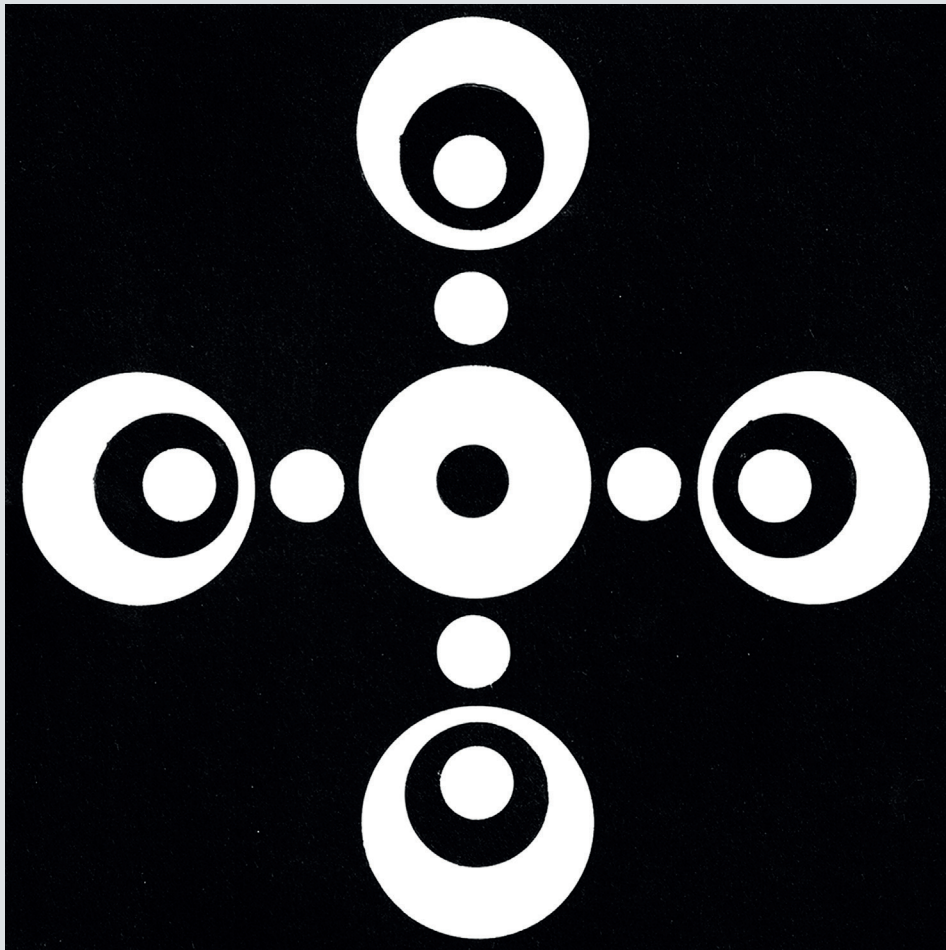

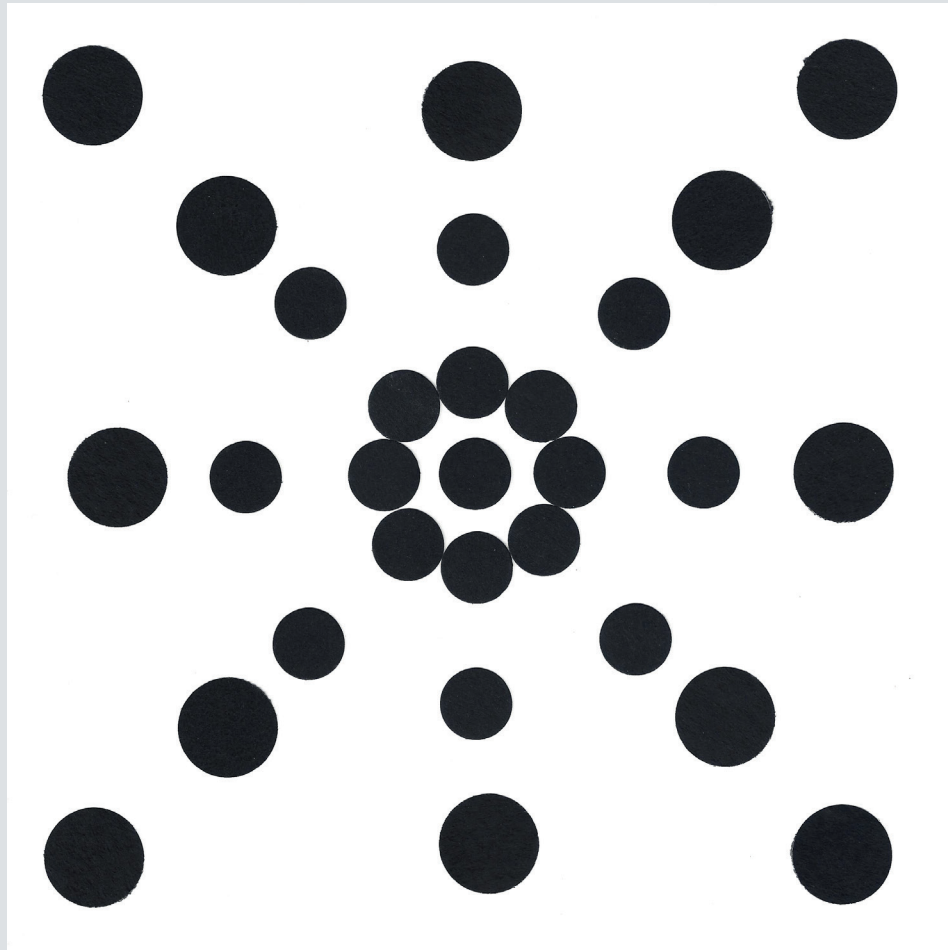
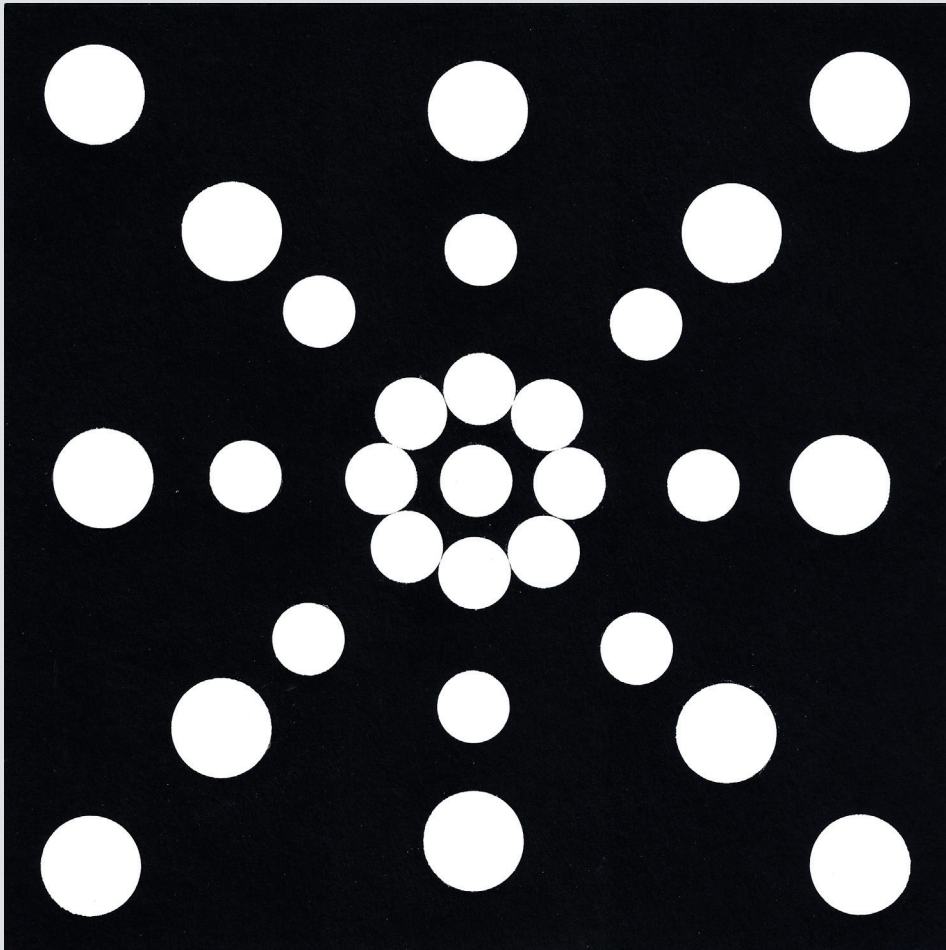

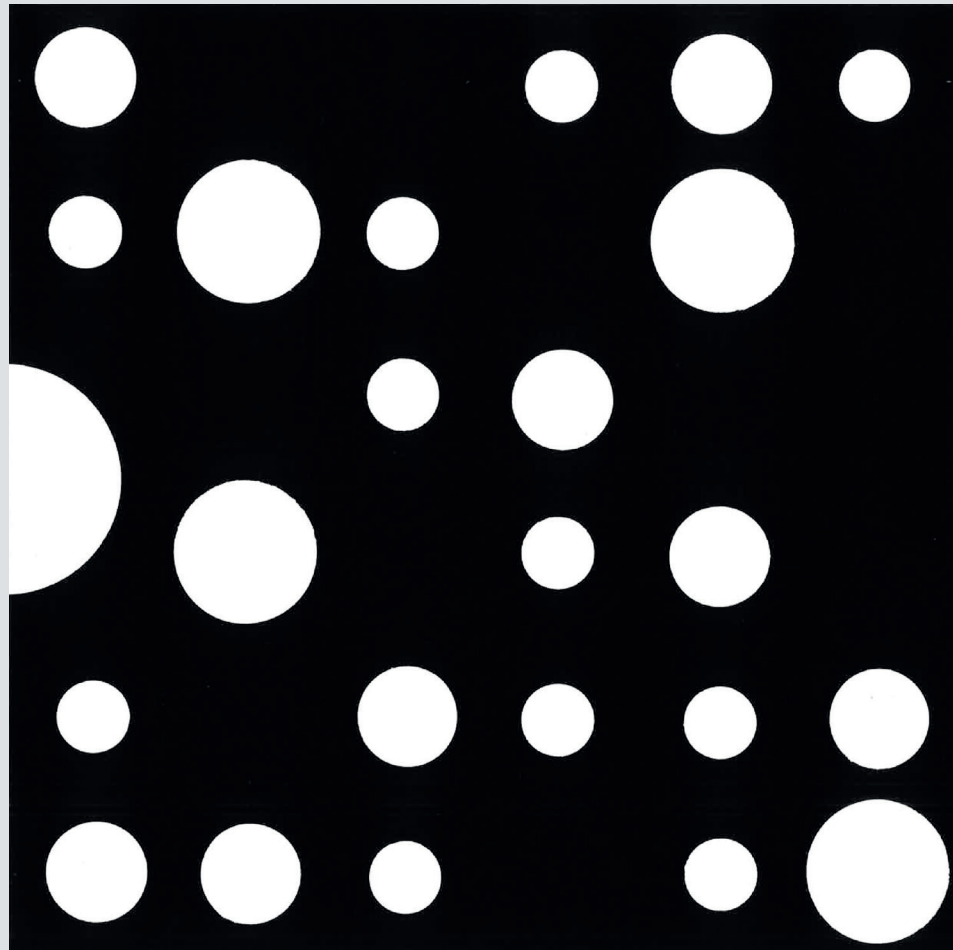
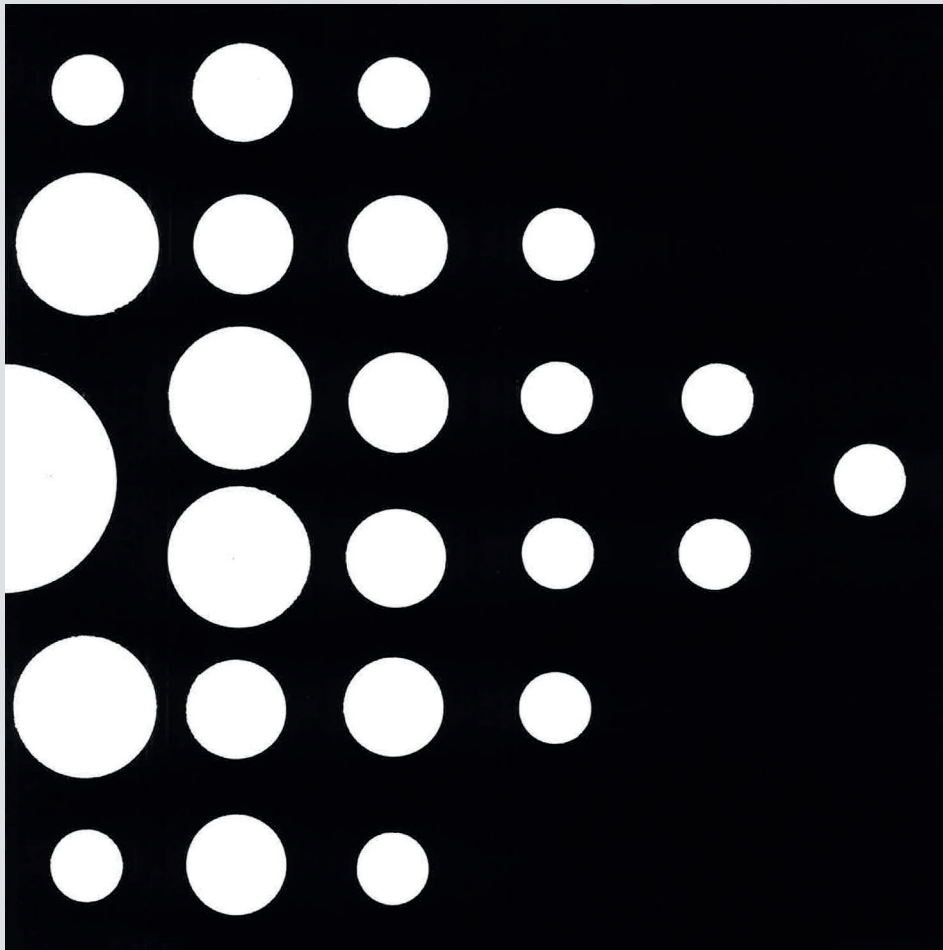

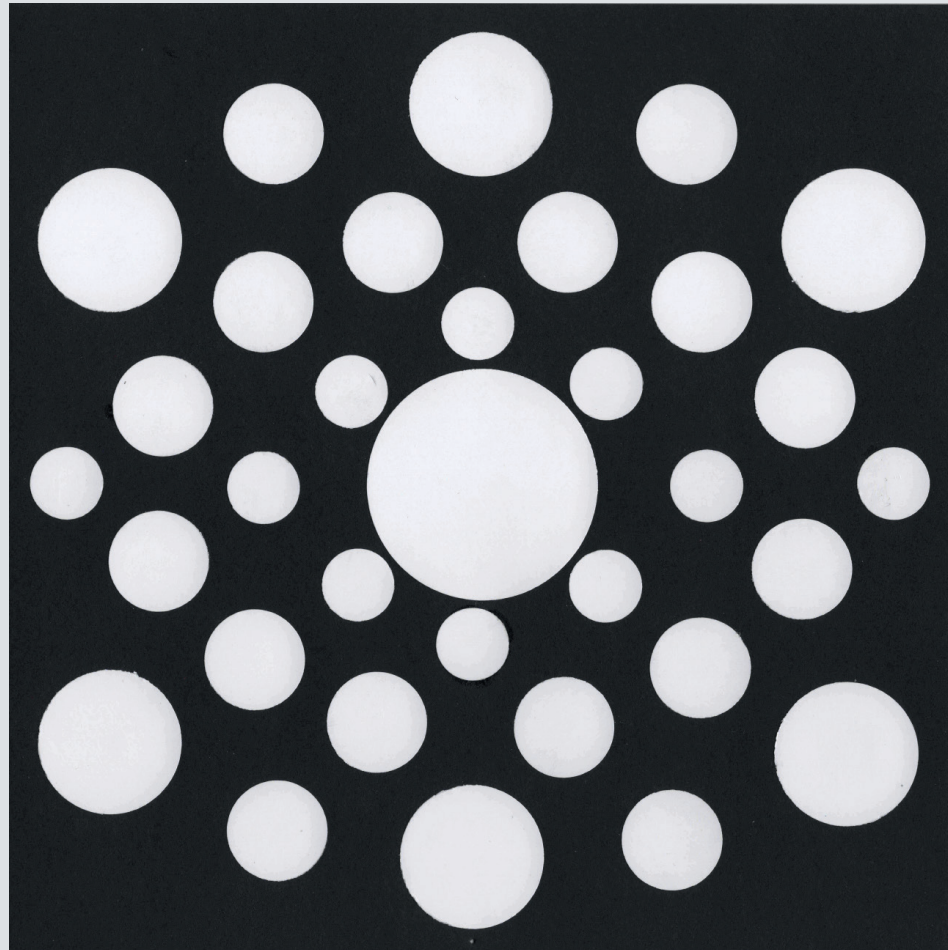
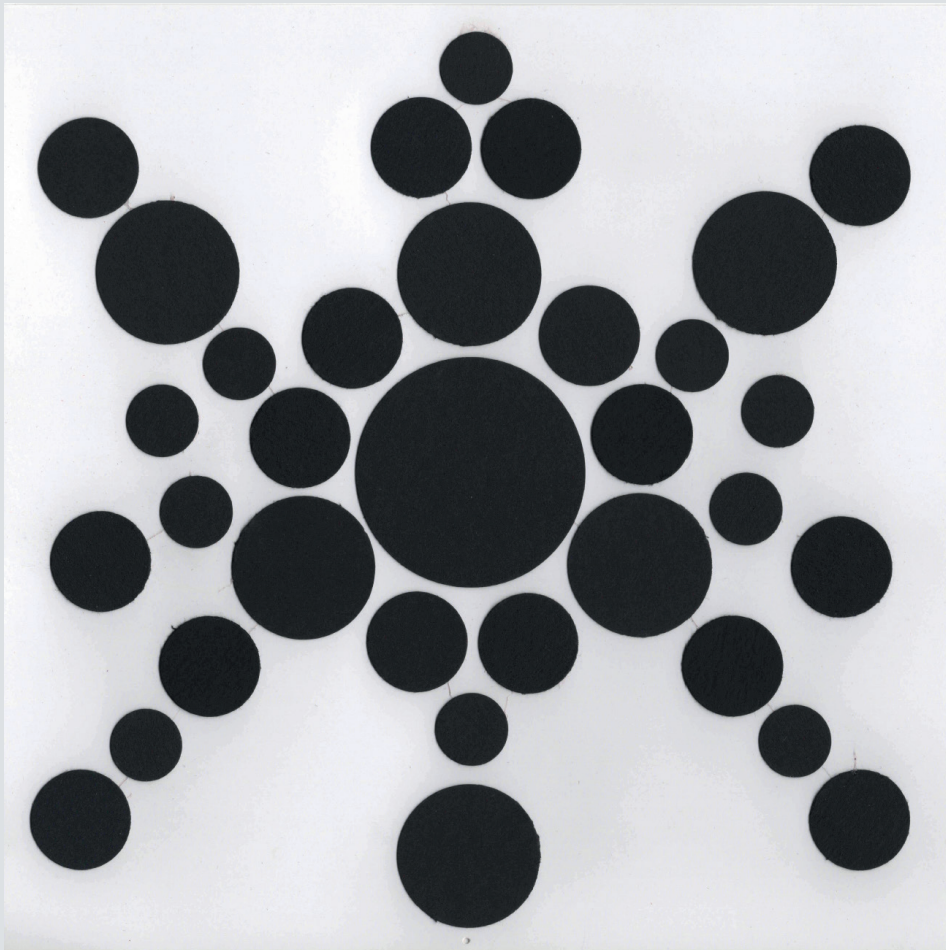

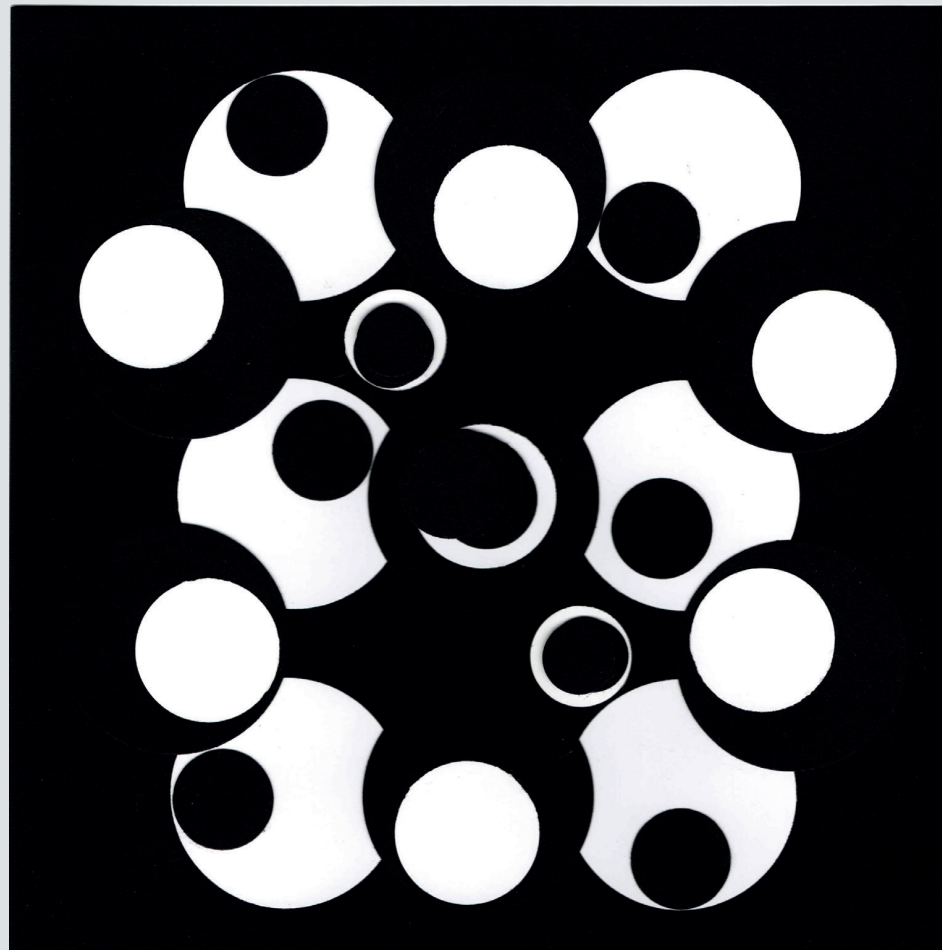
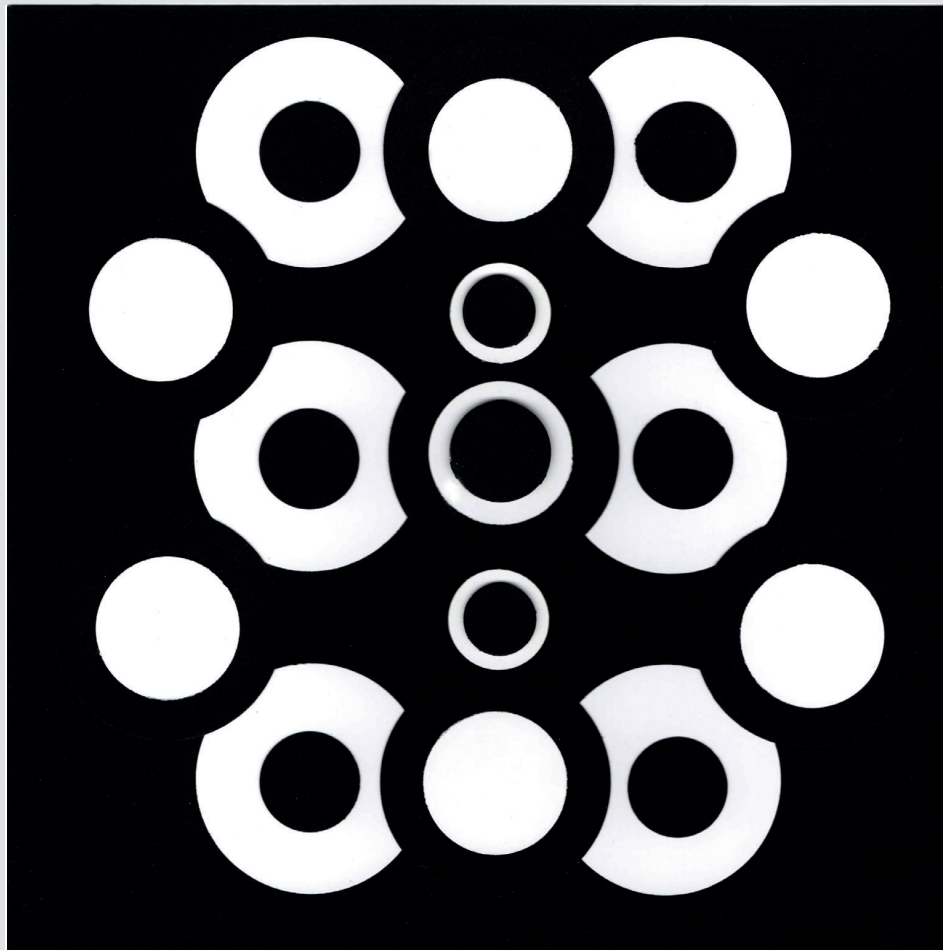

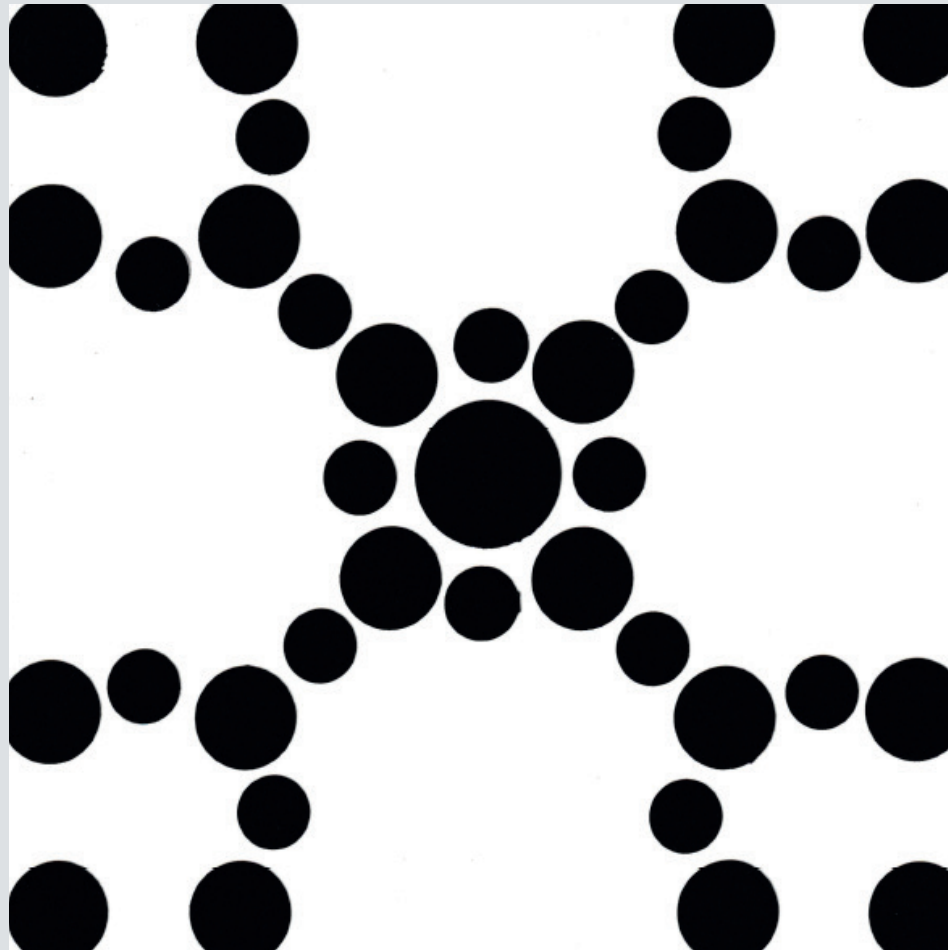
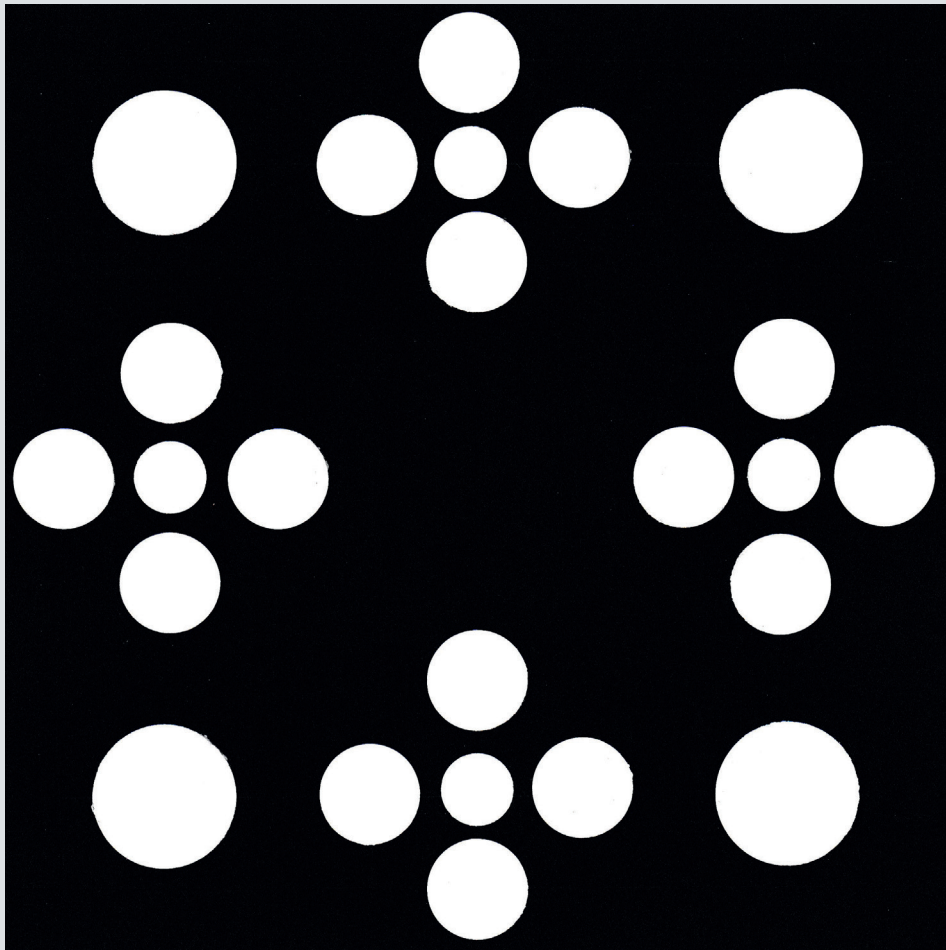

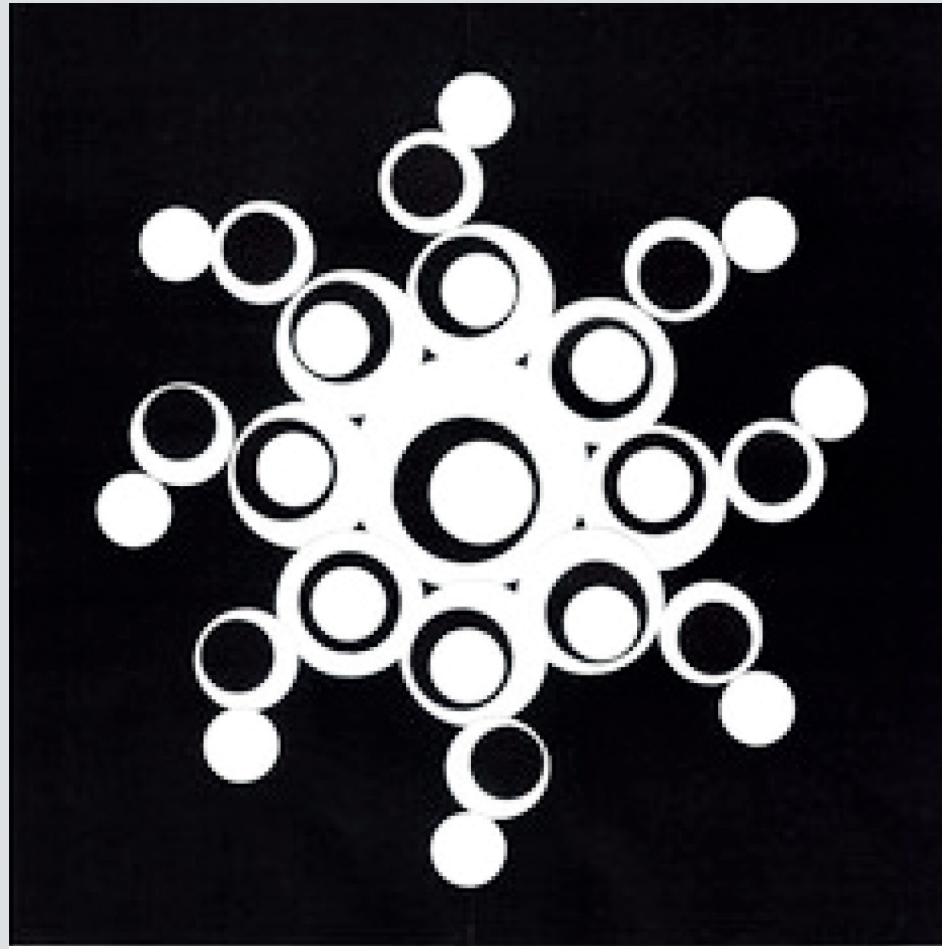
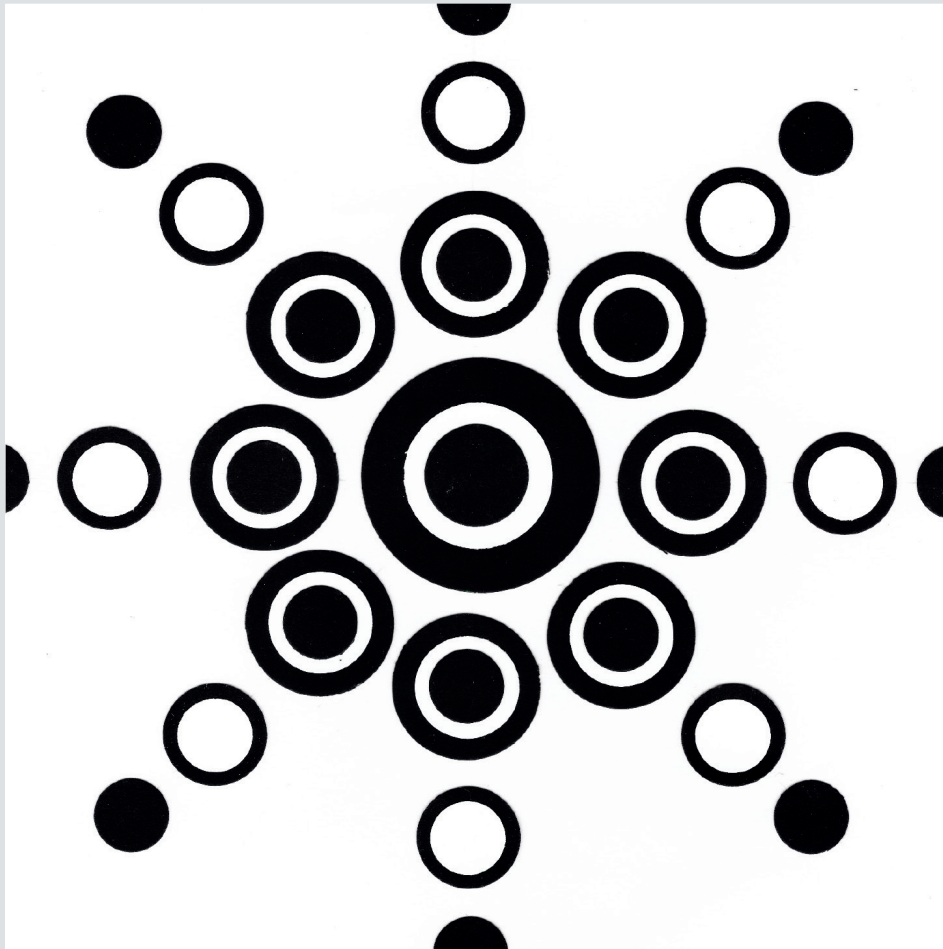

LINIE

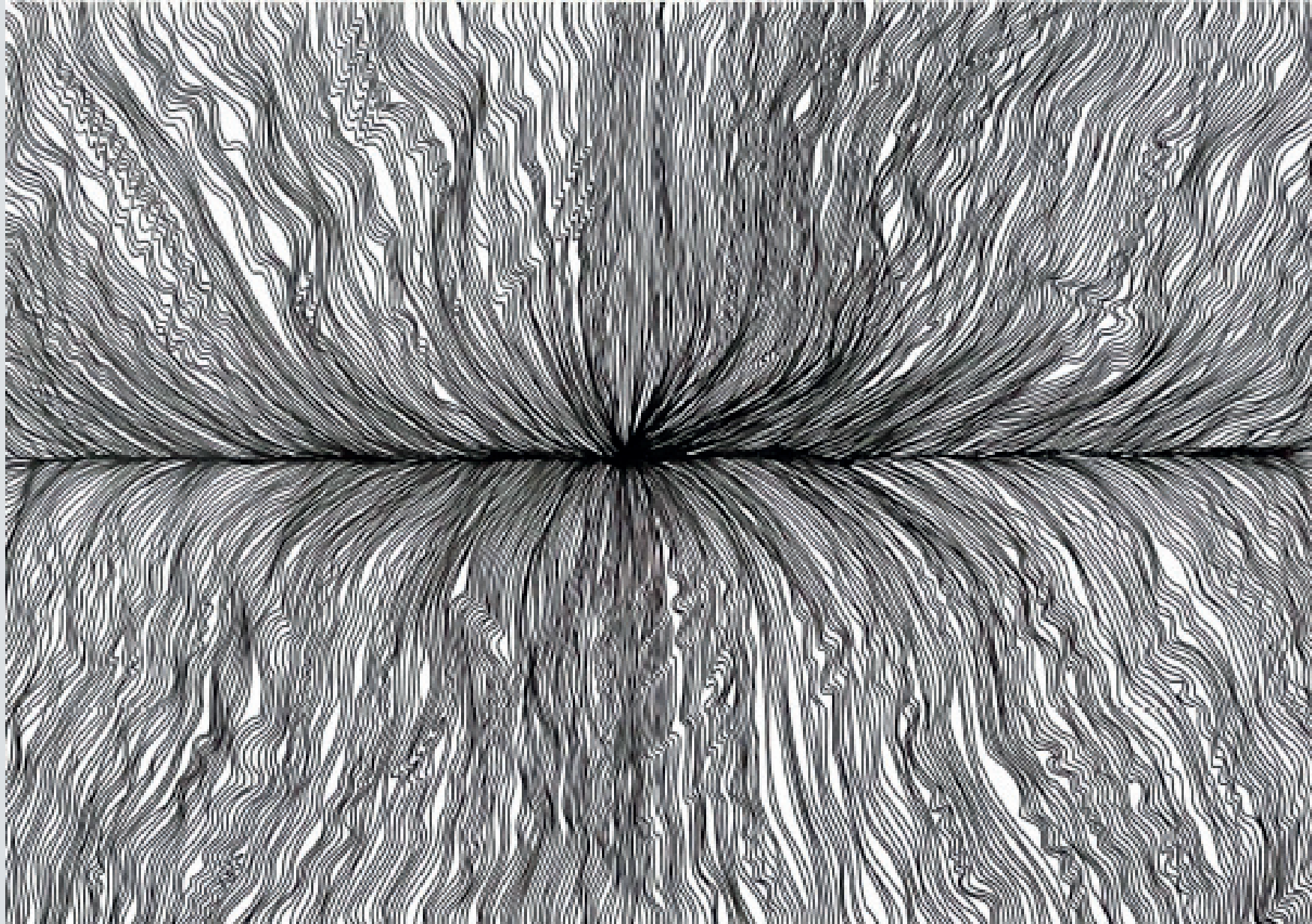



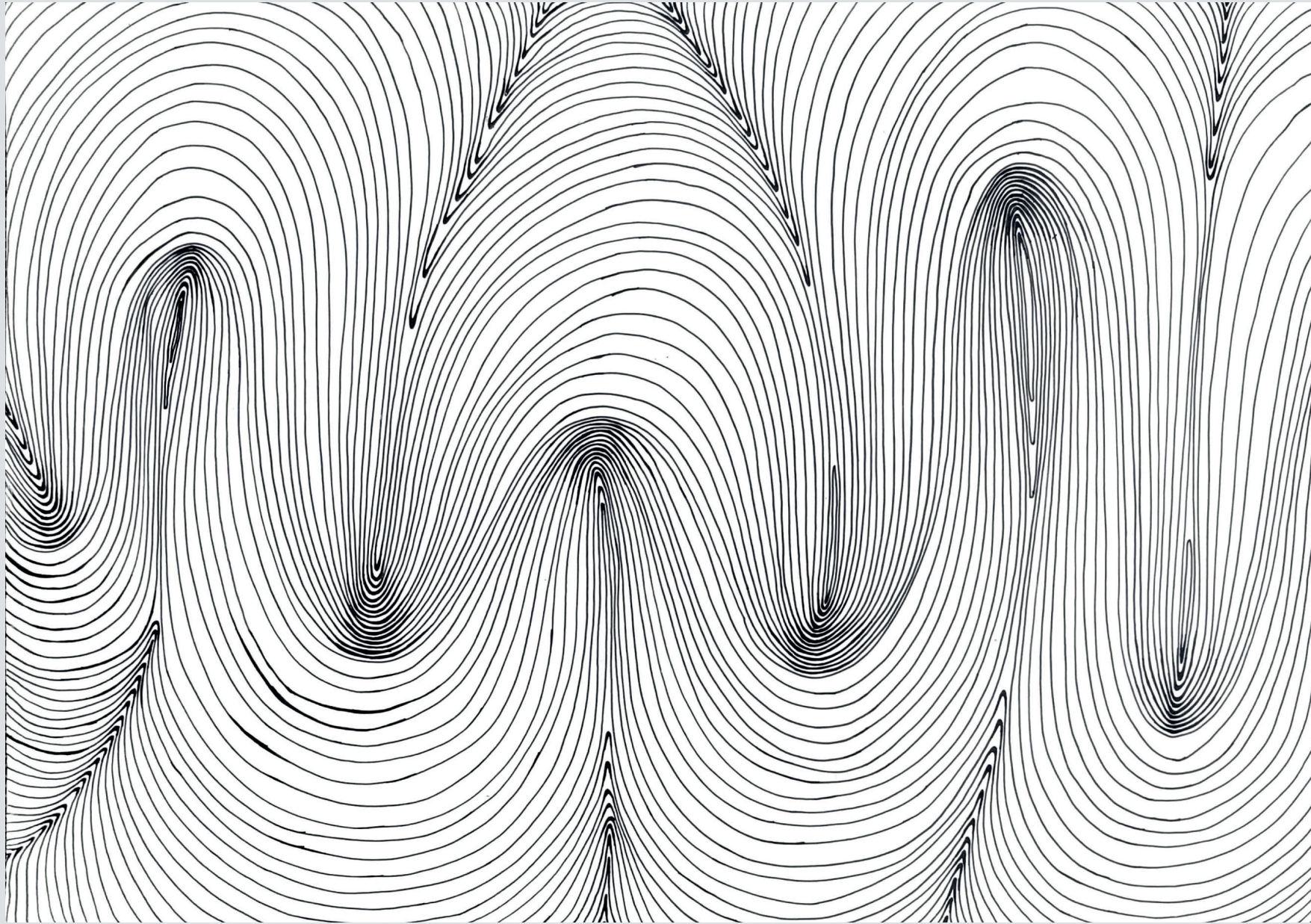

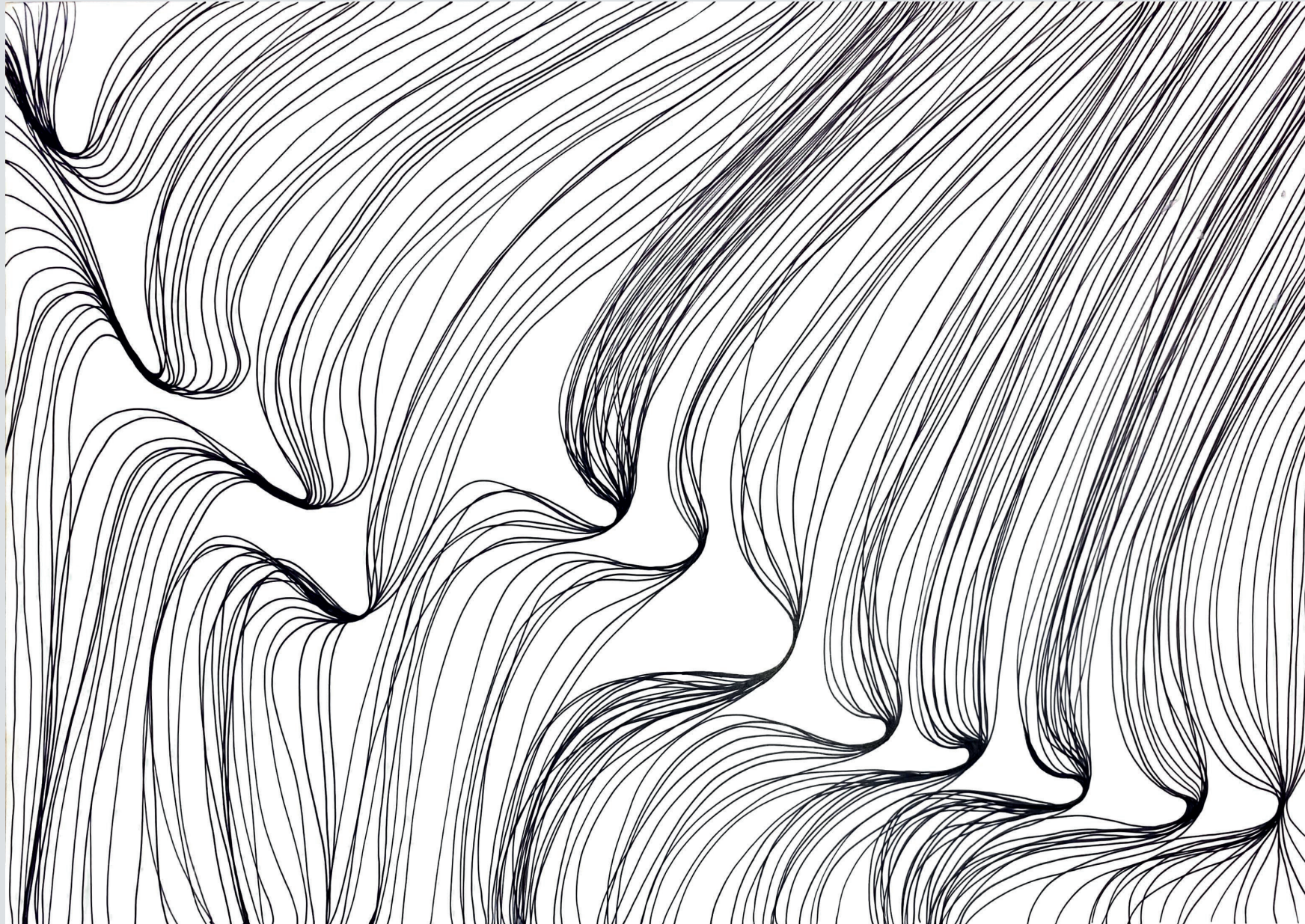

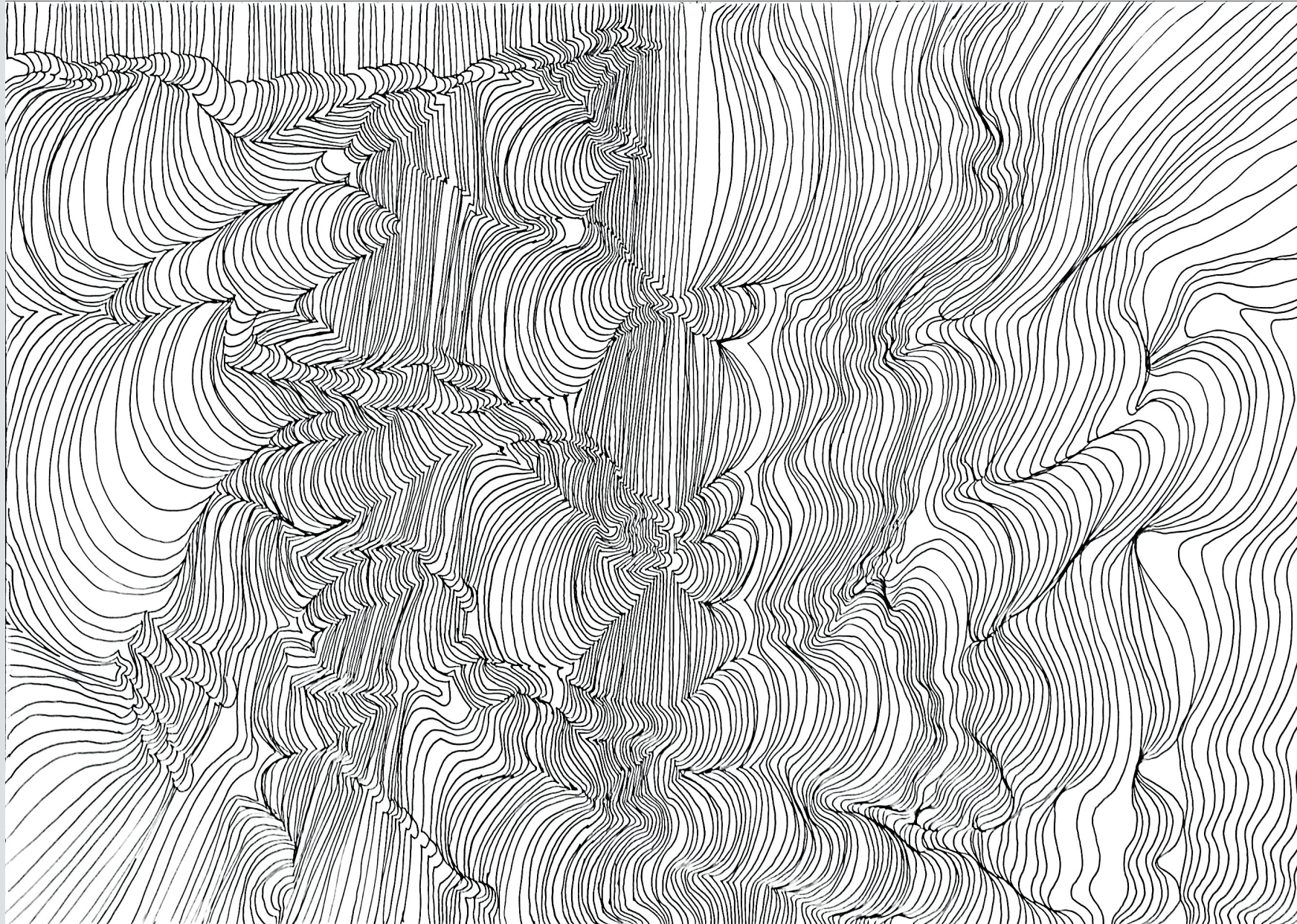

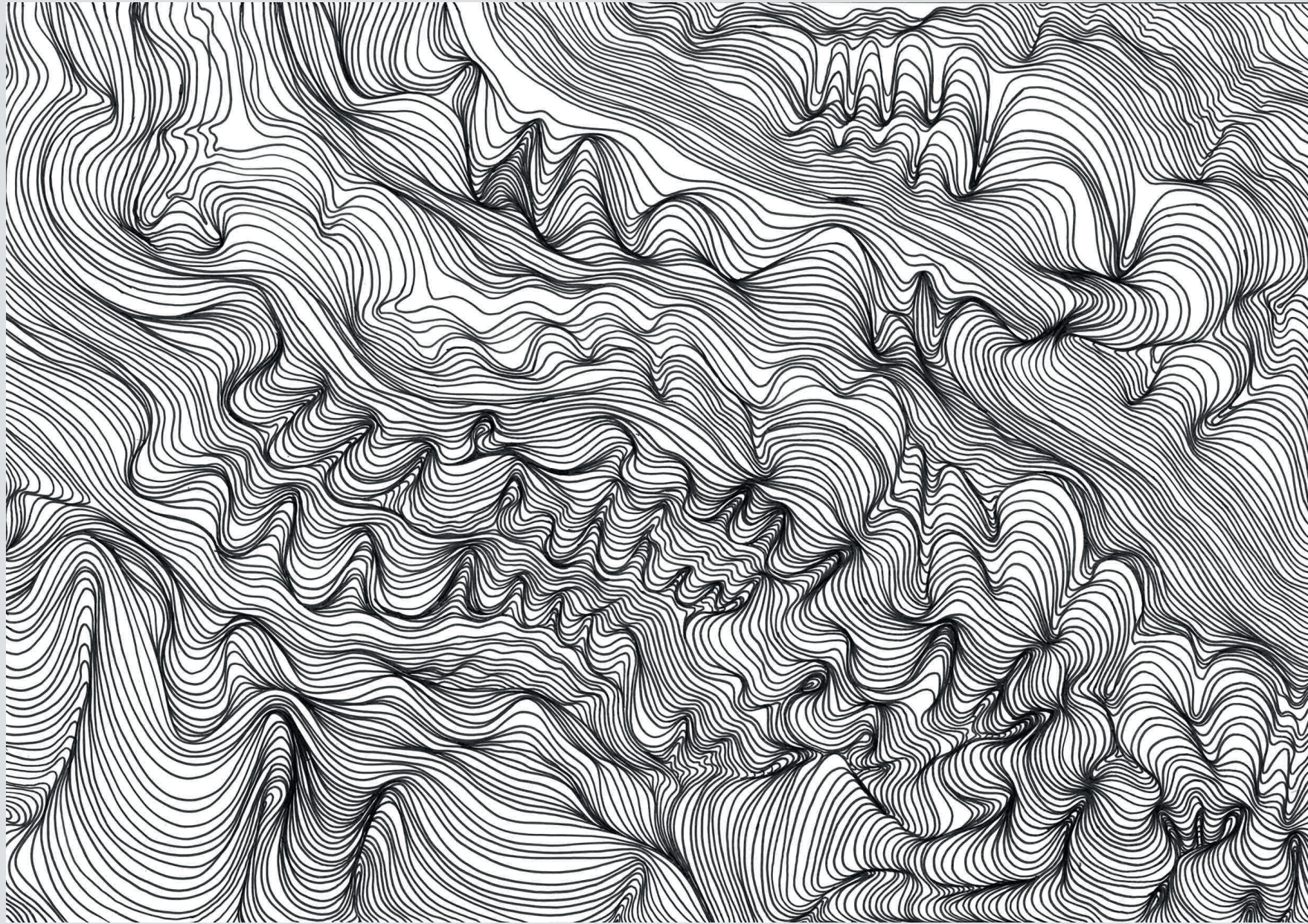

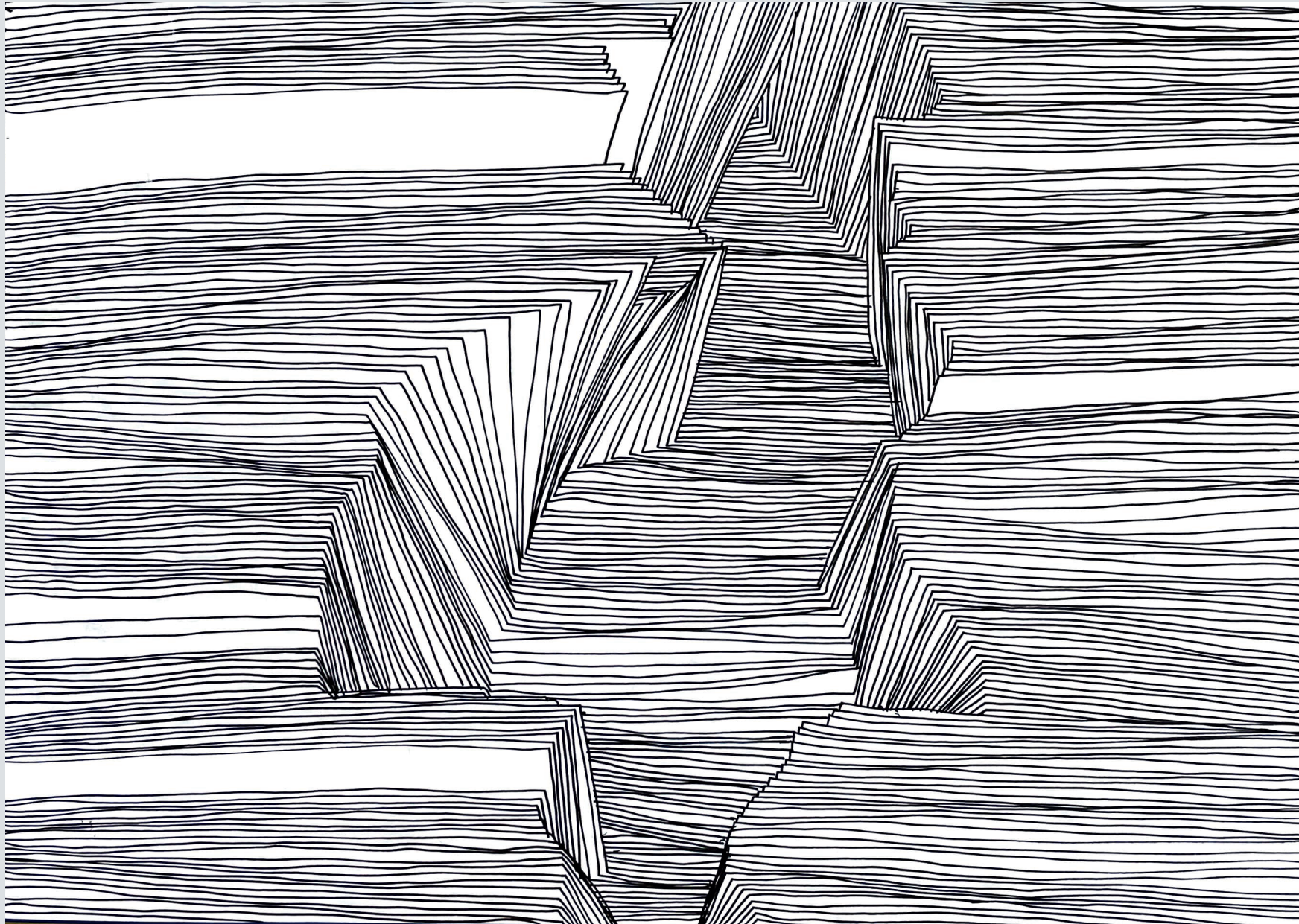

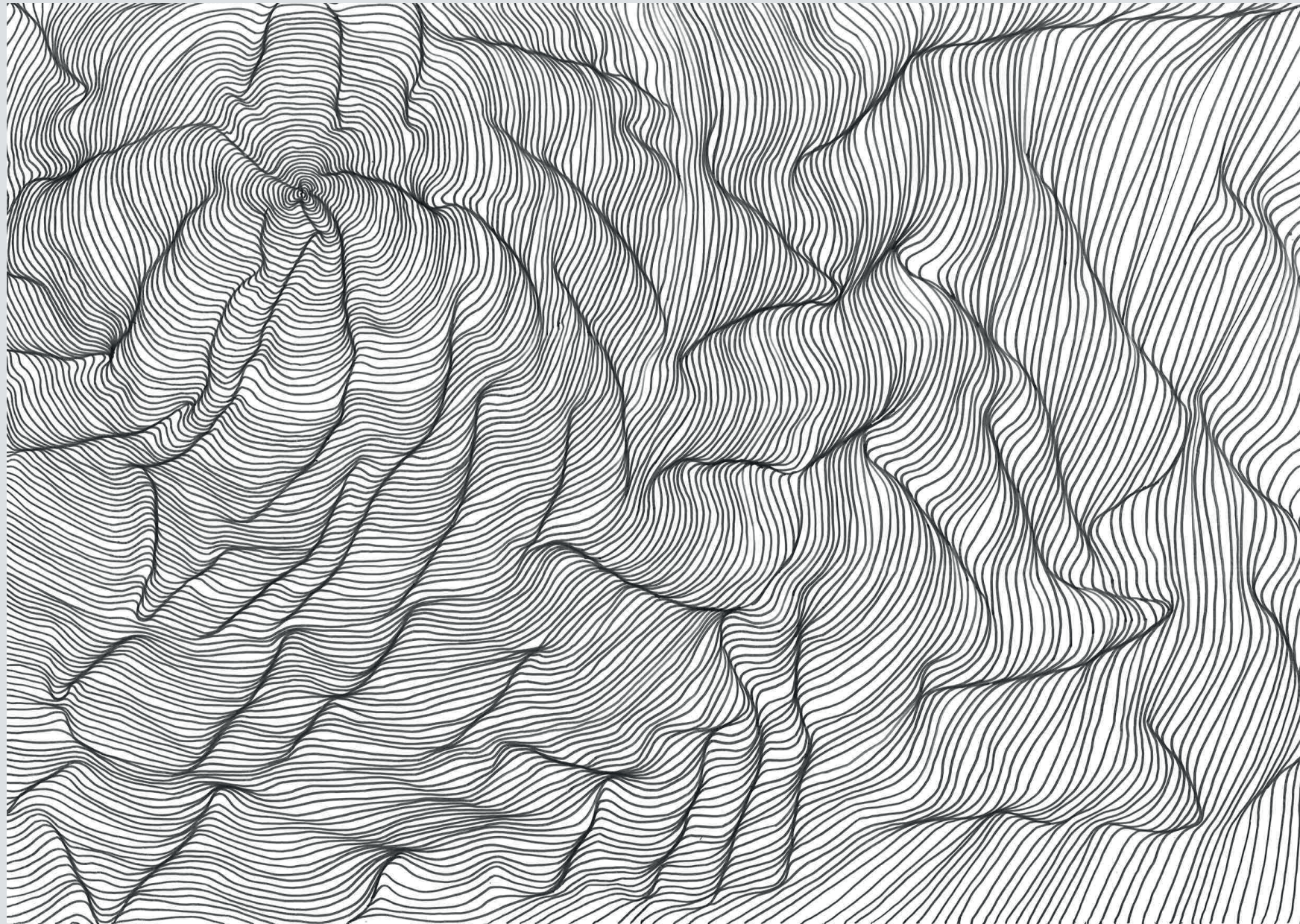

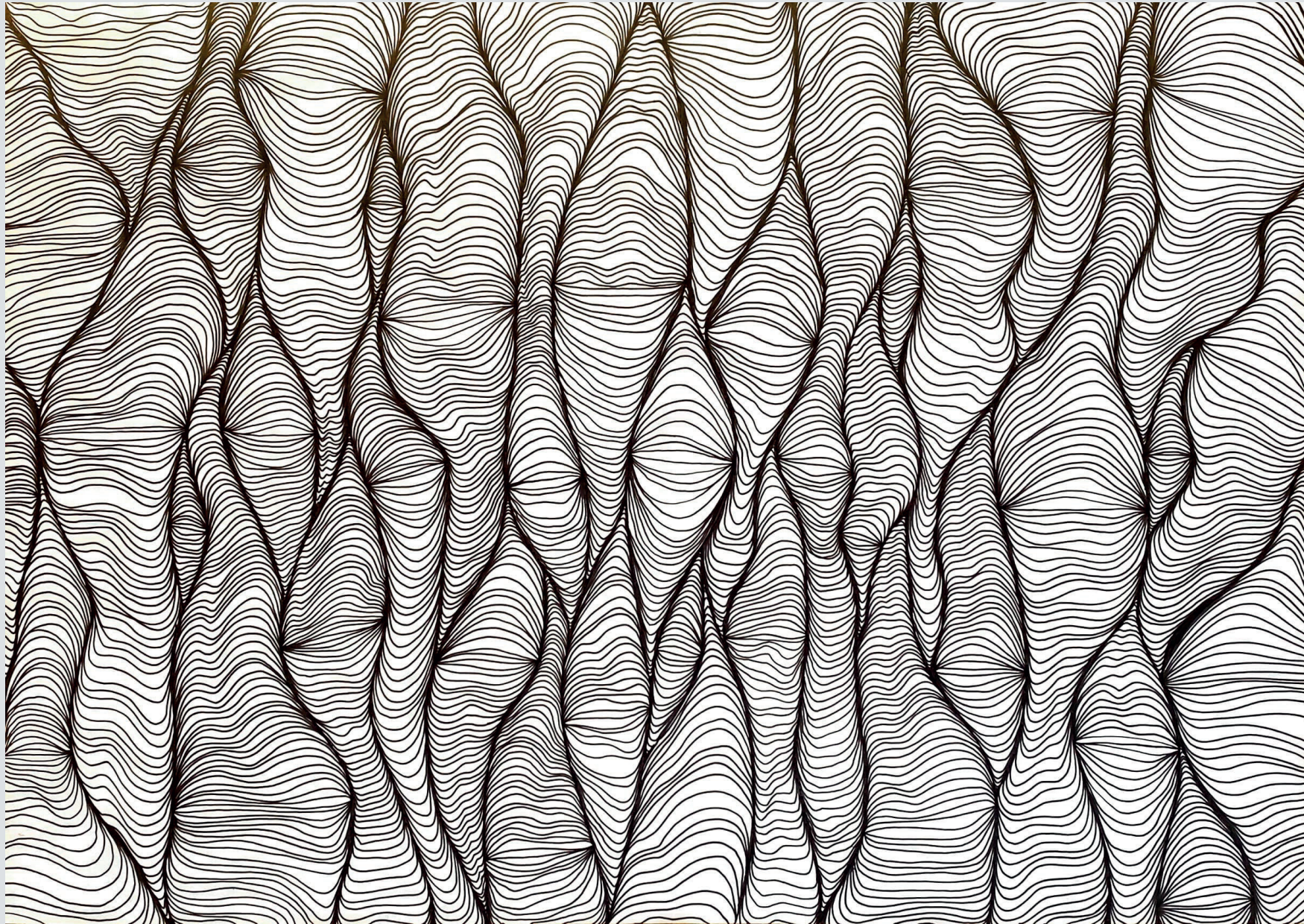

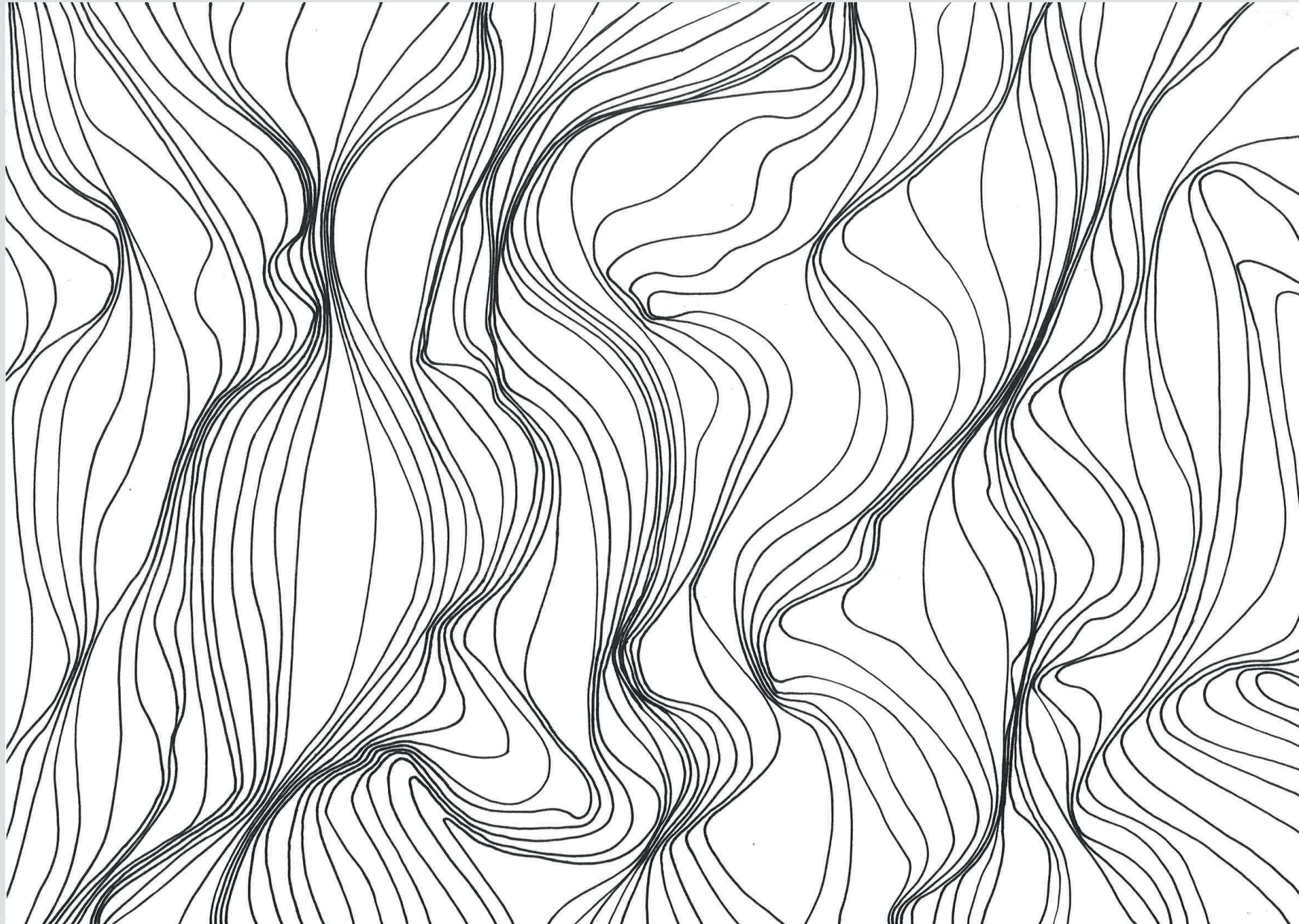

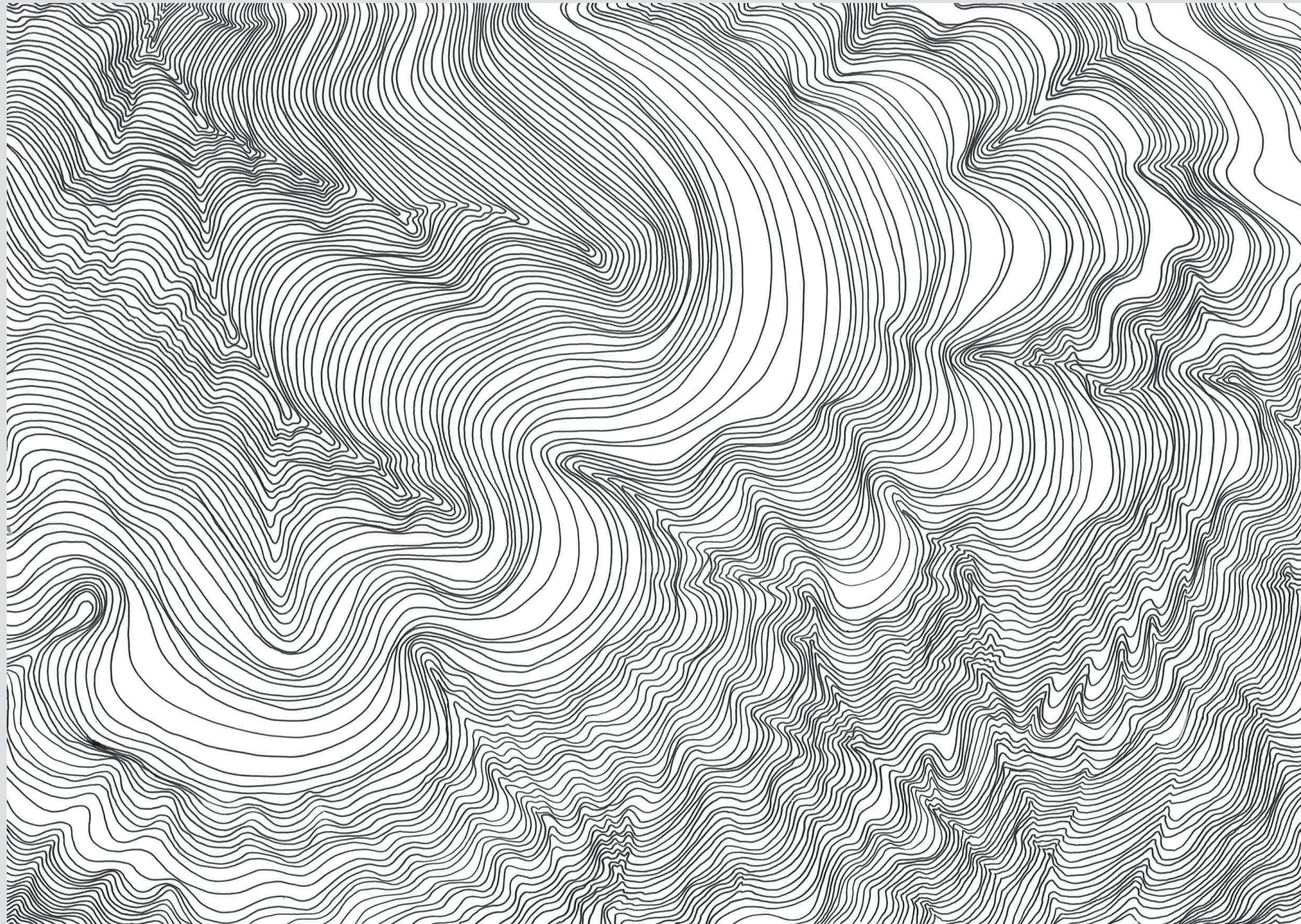

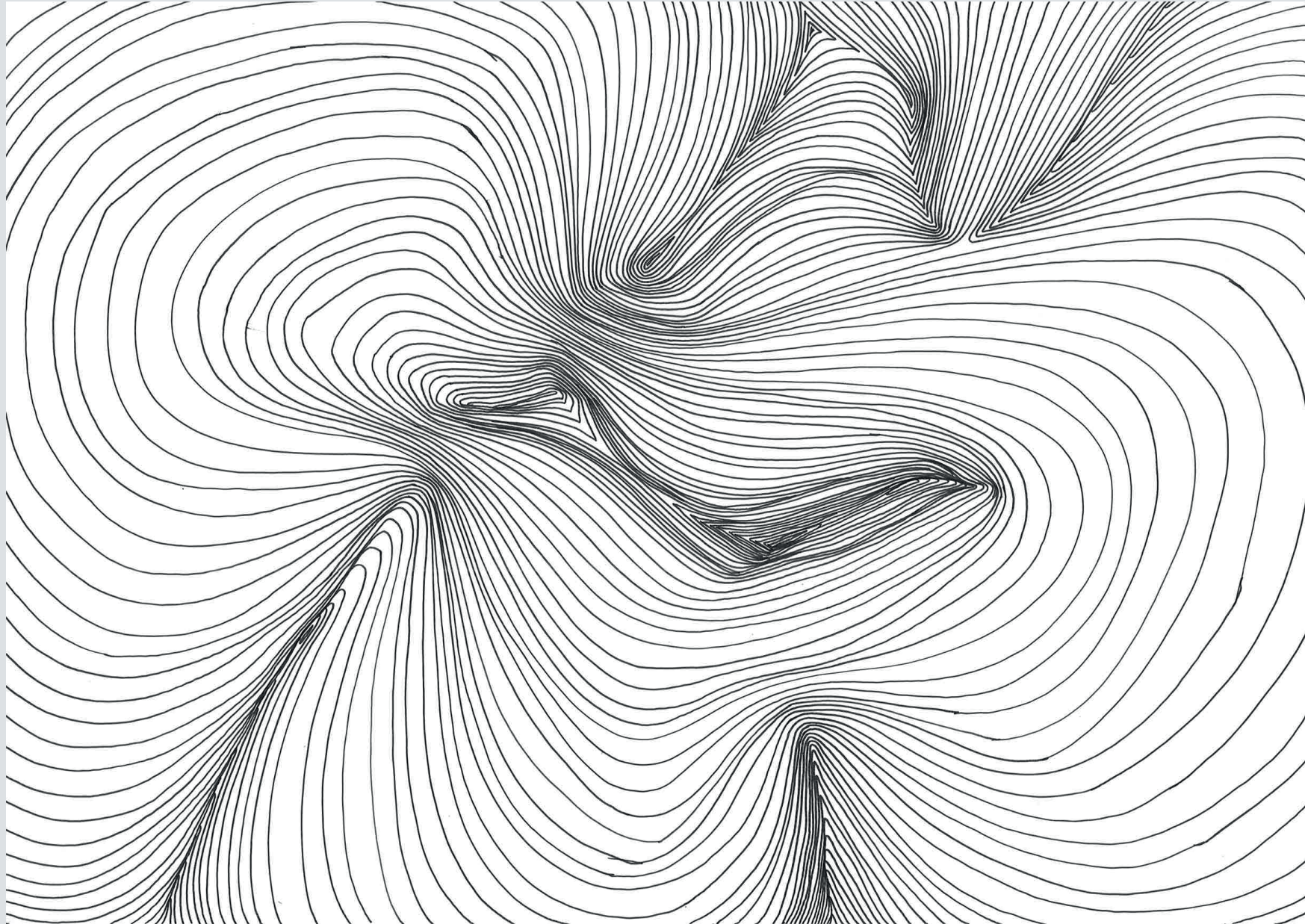

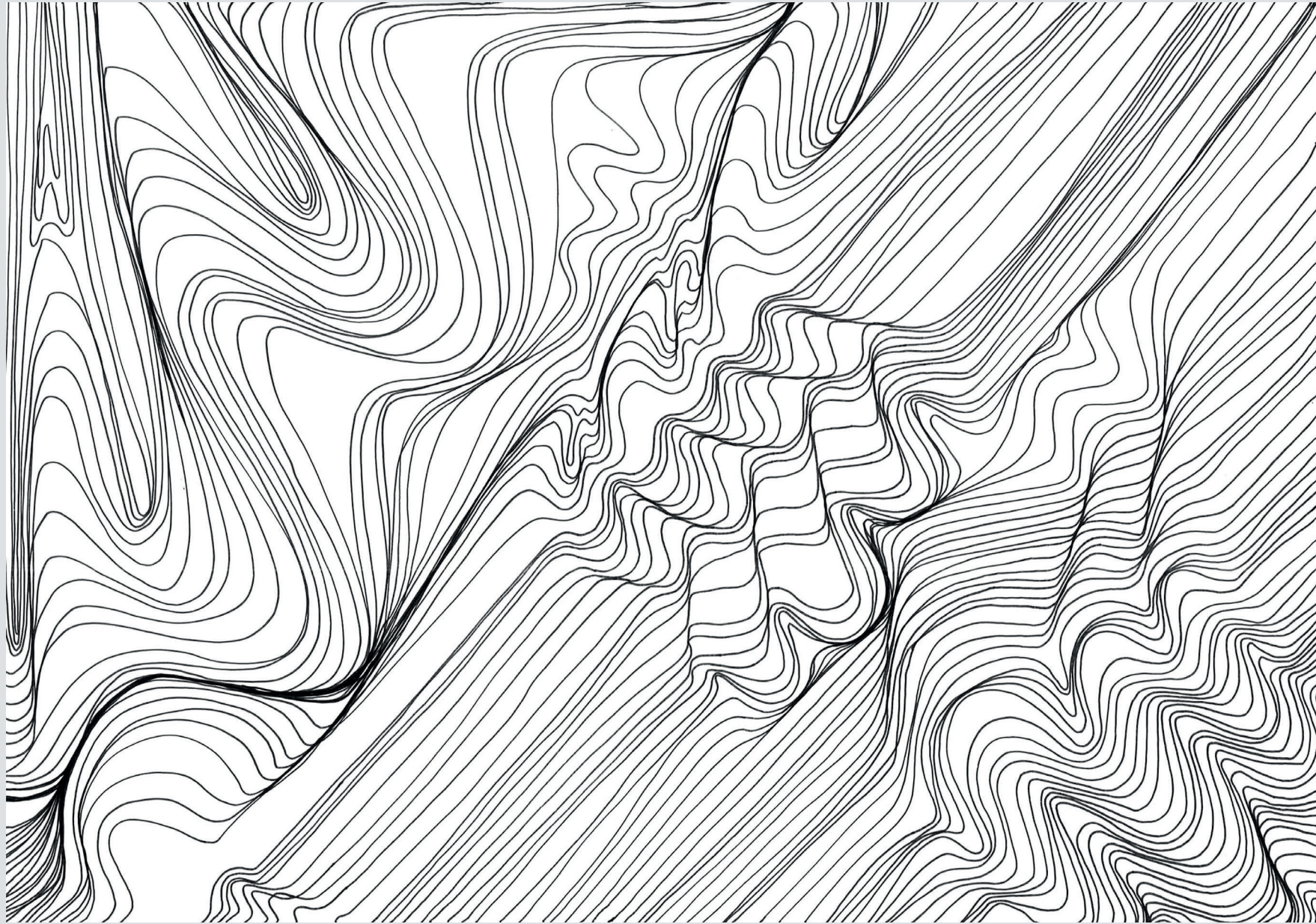

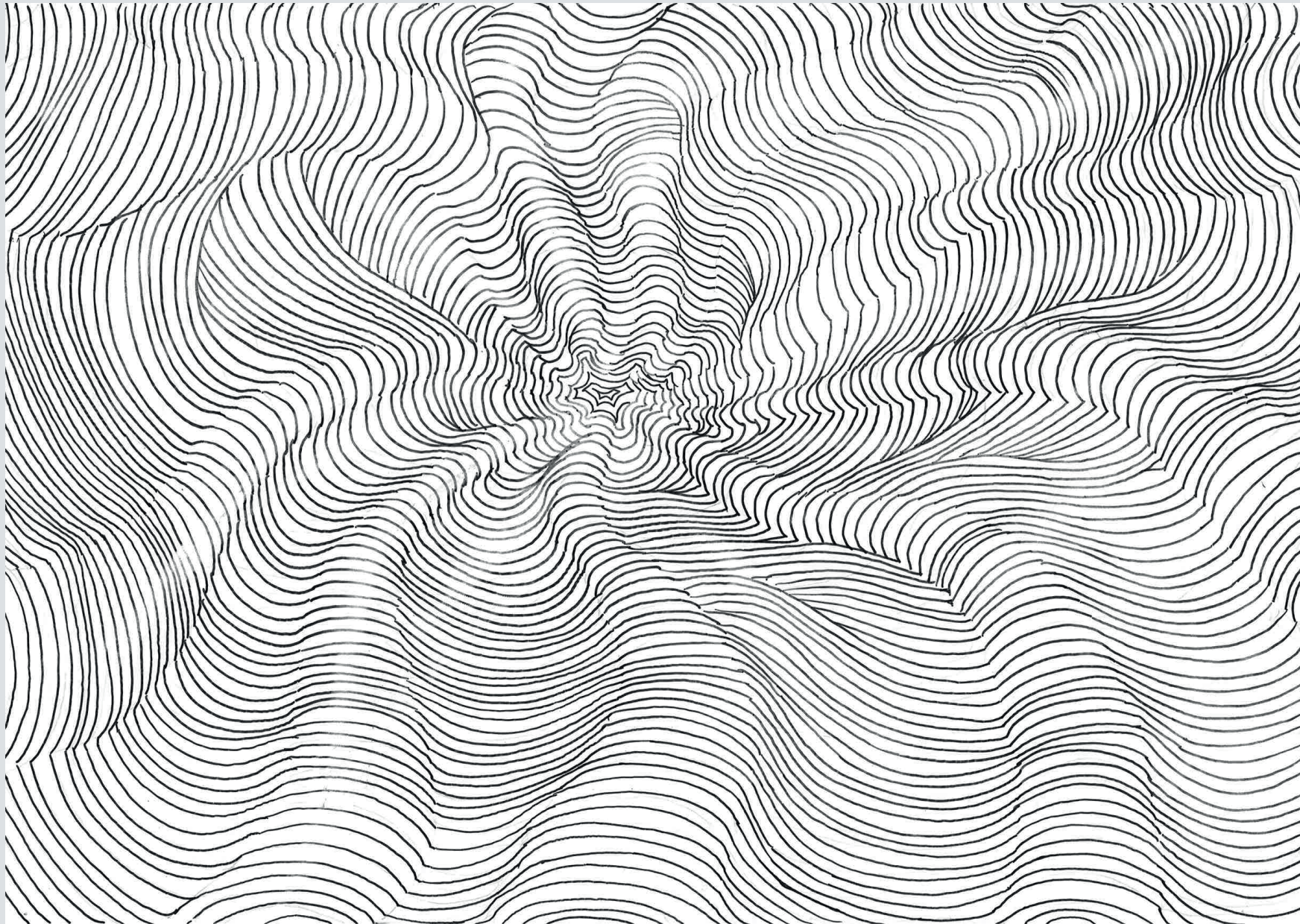

FLÄCHE

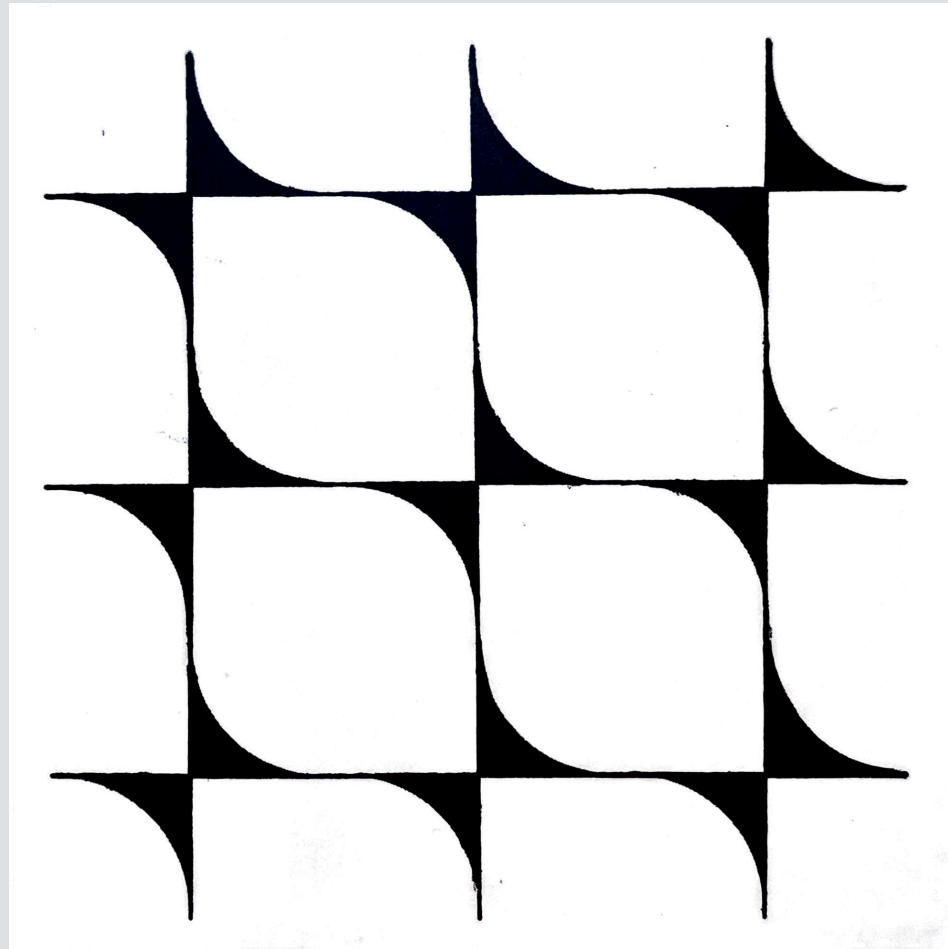
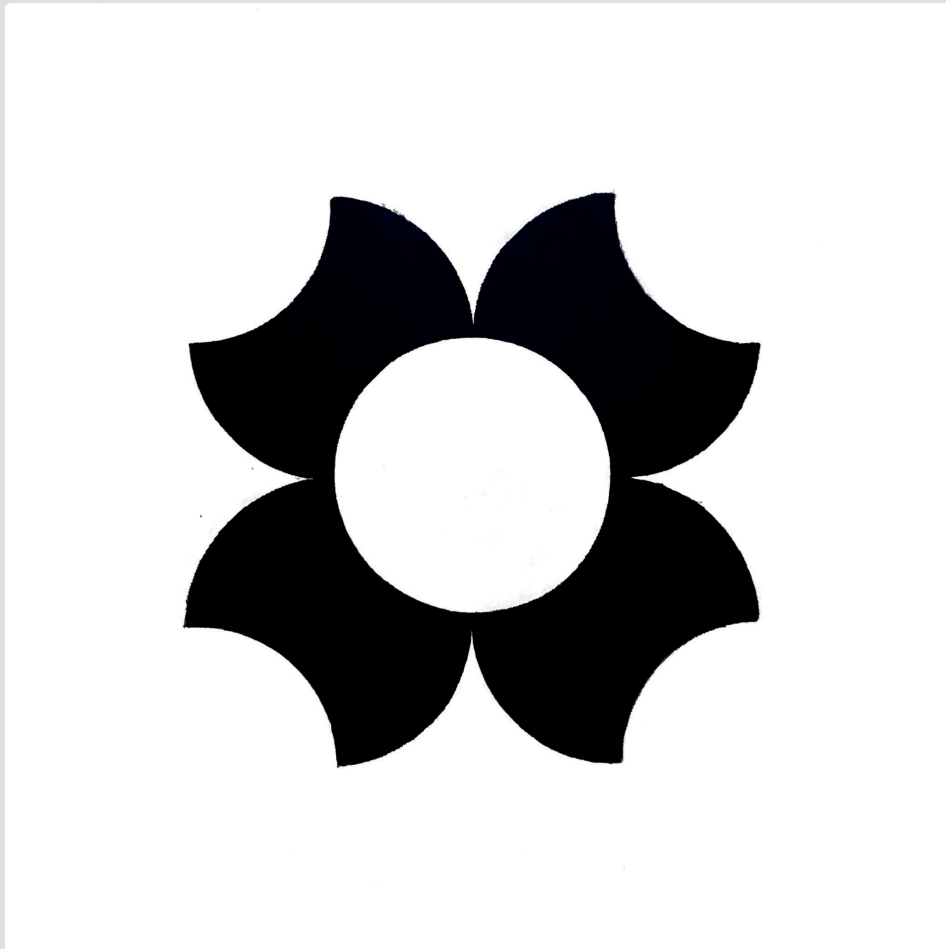

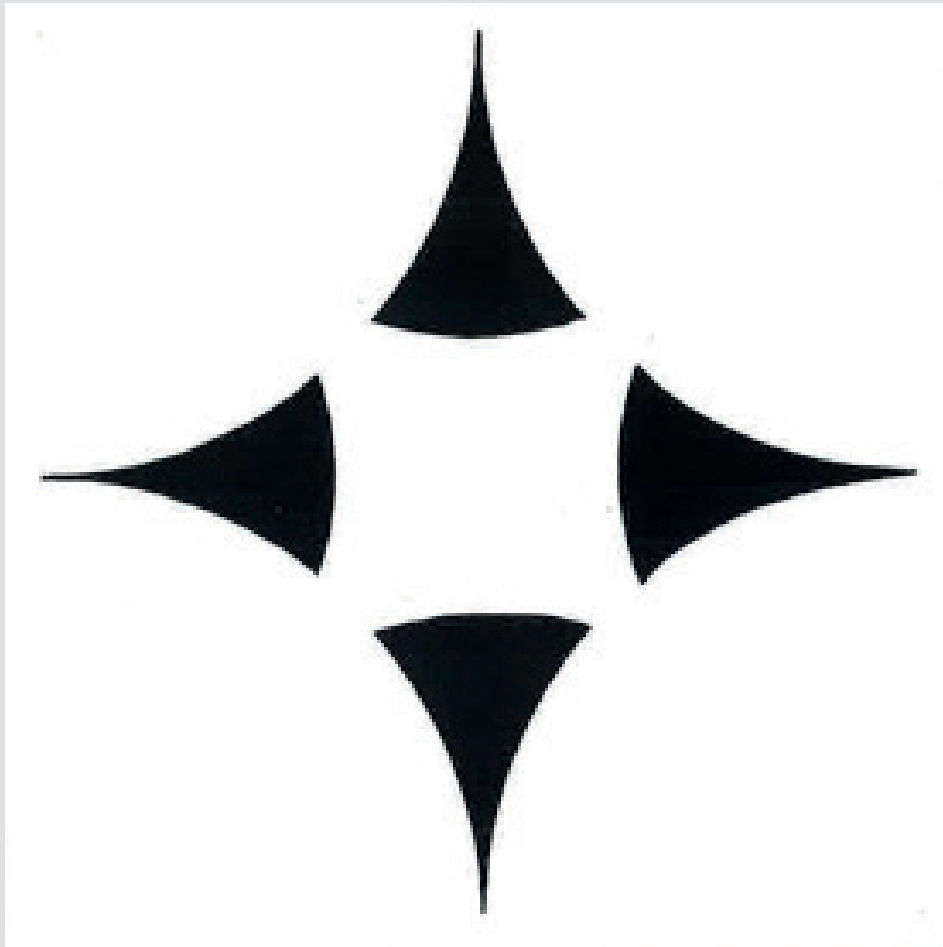



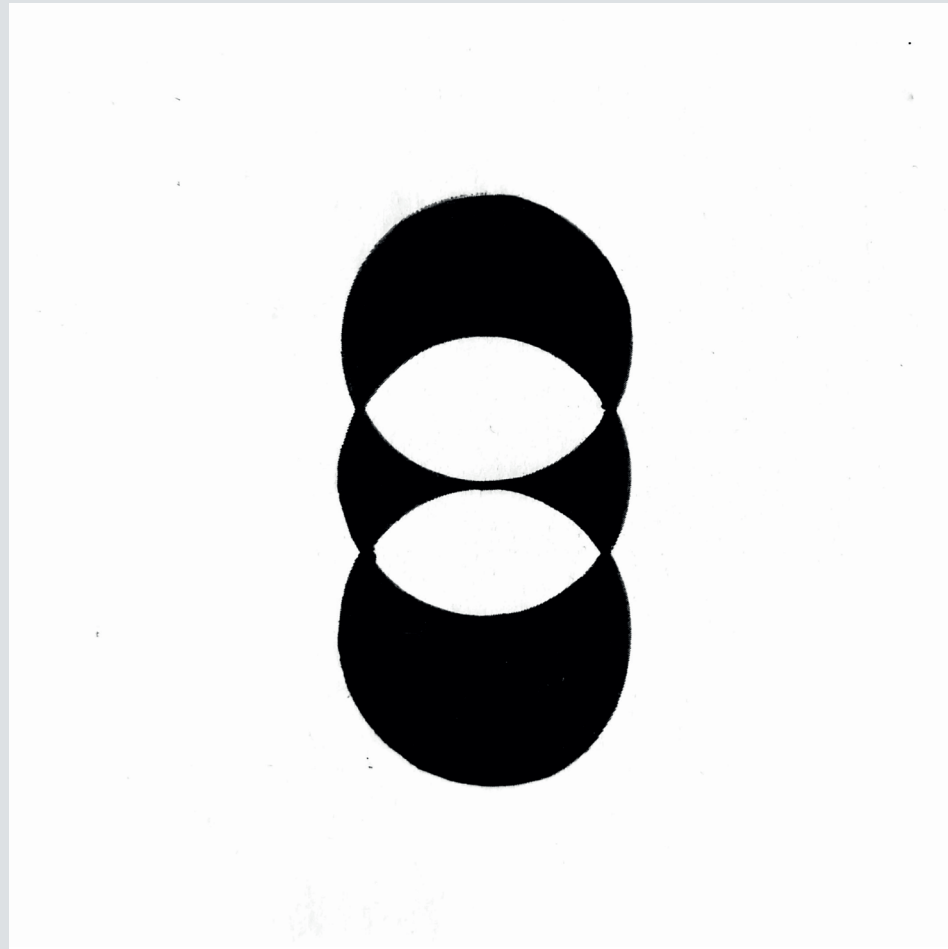
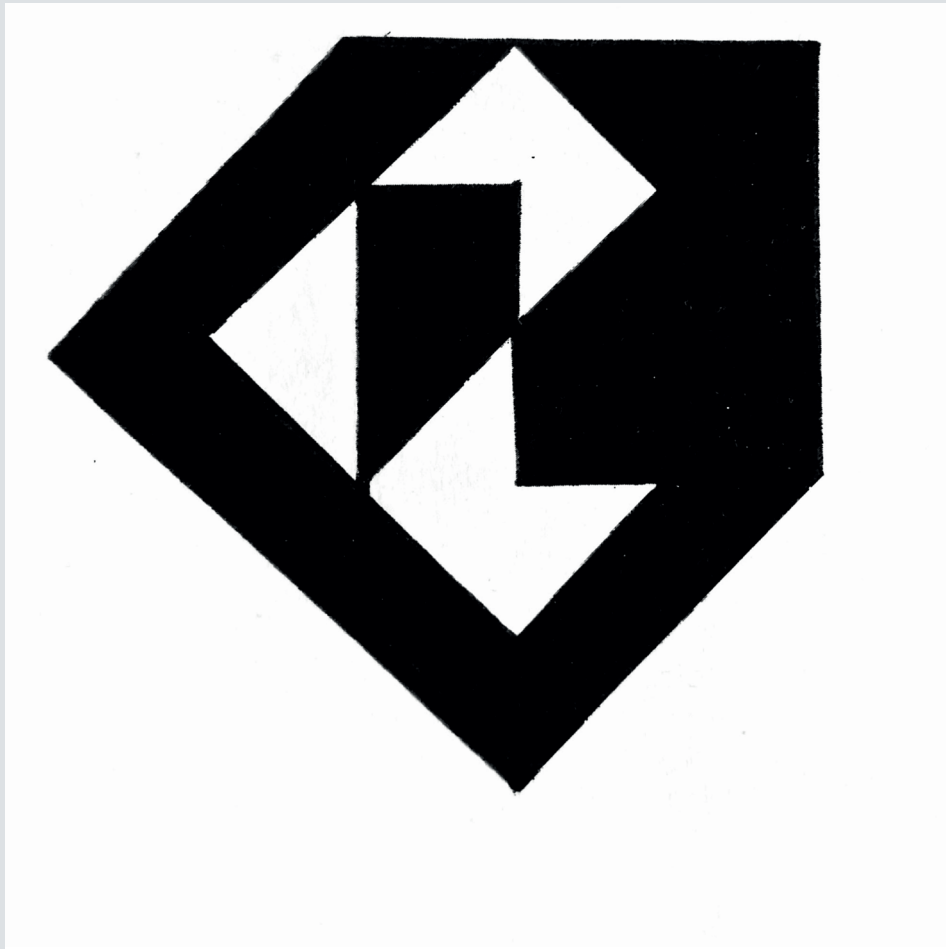

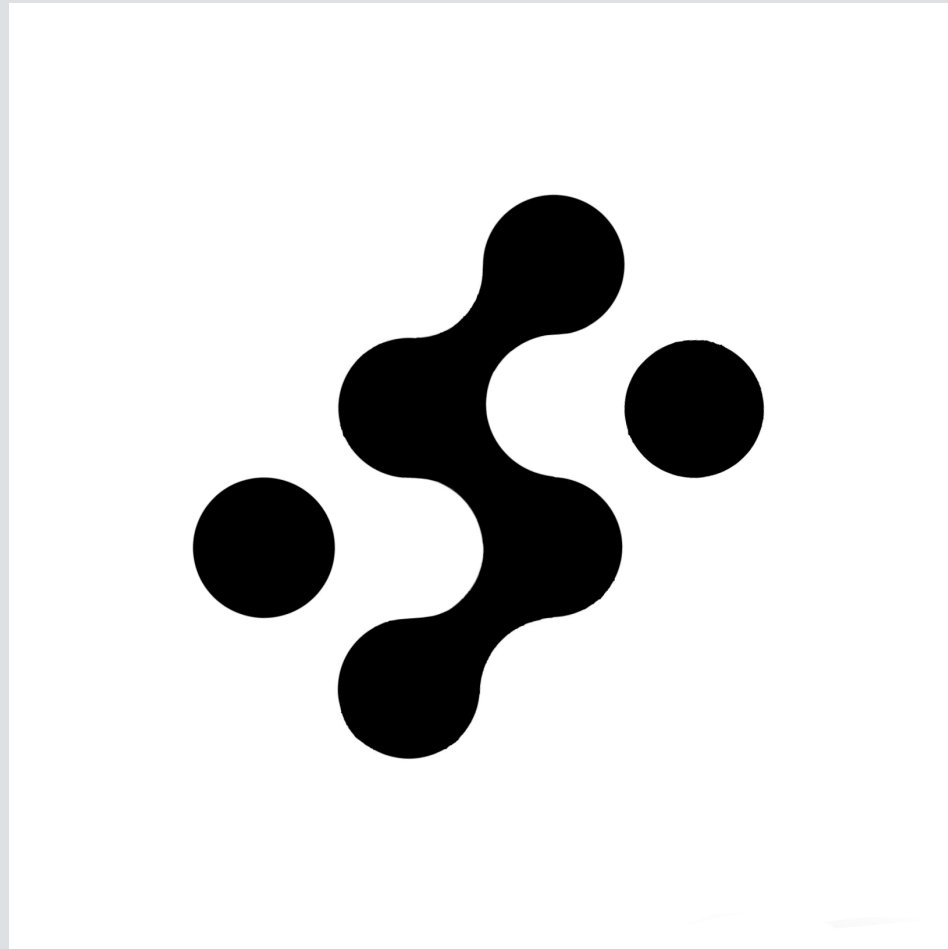
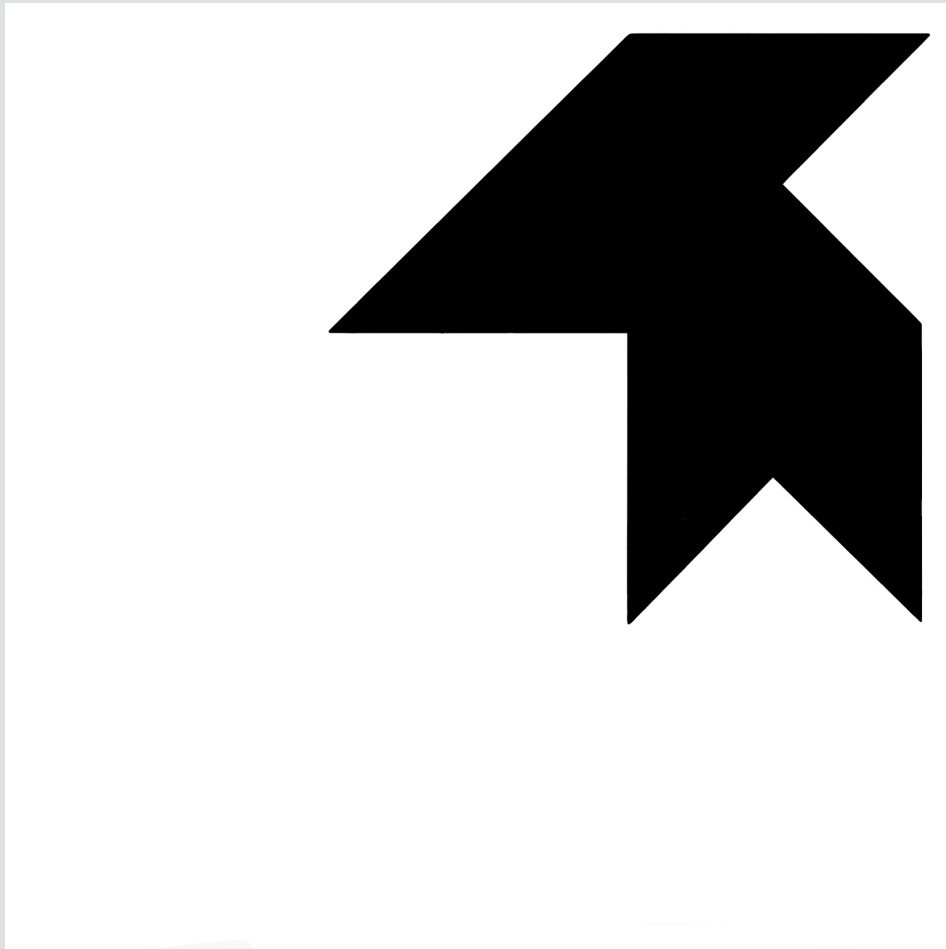

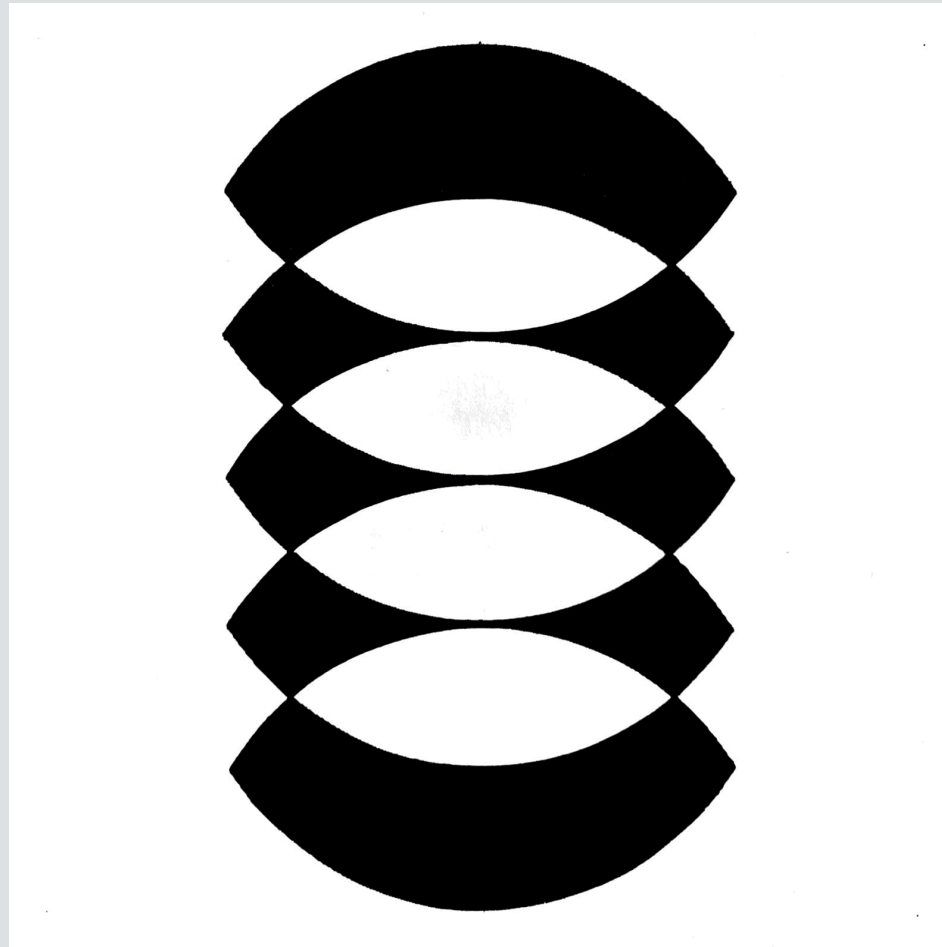
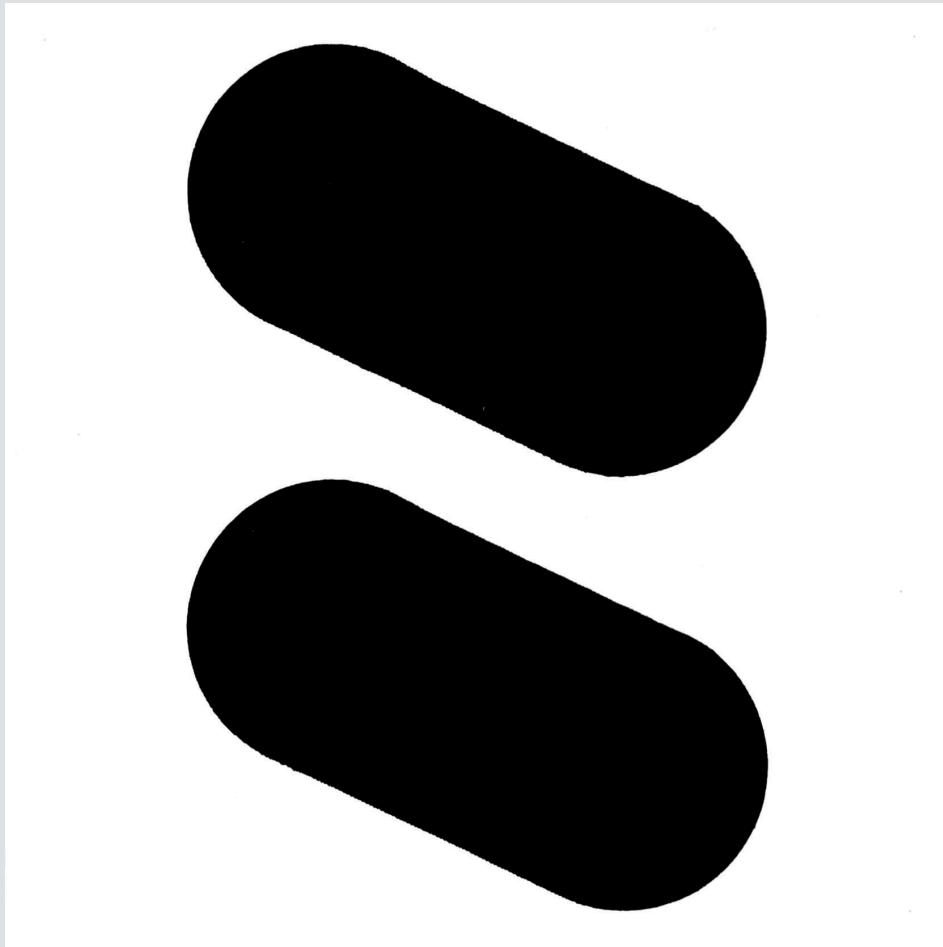

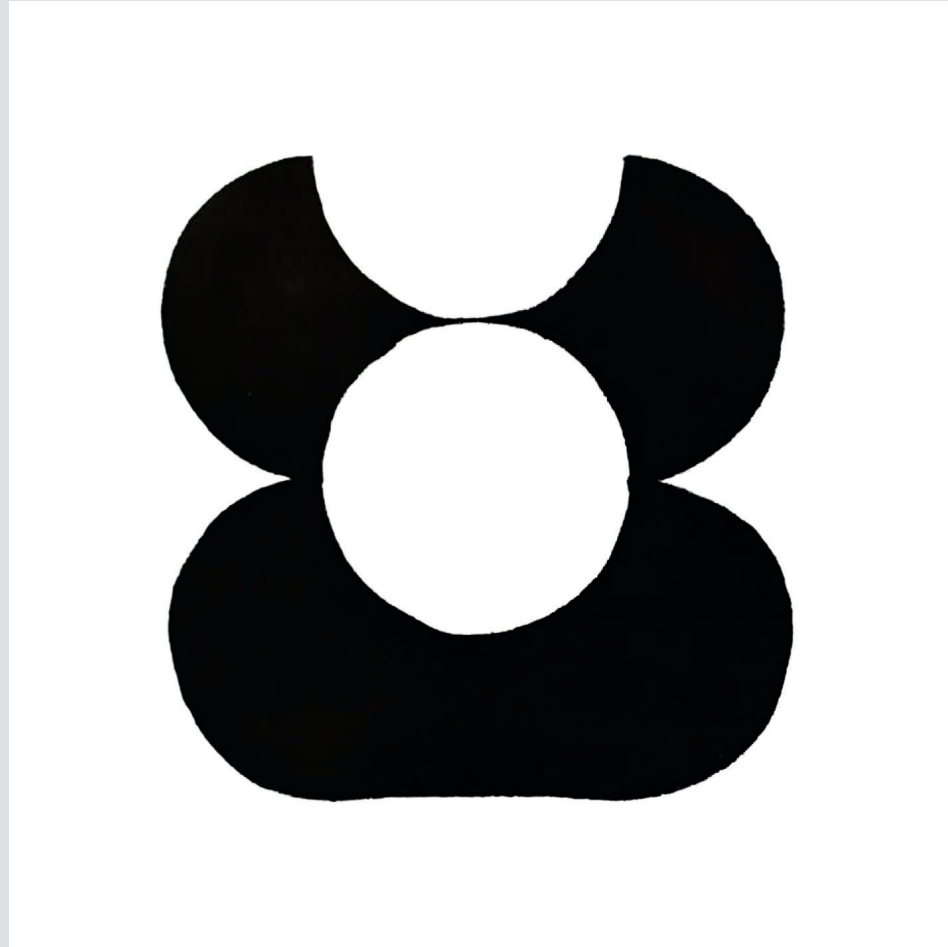

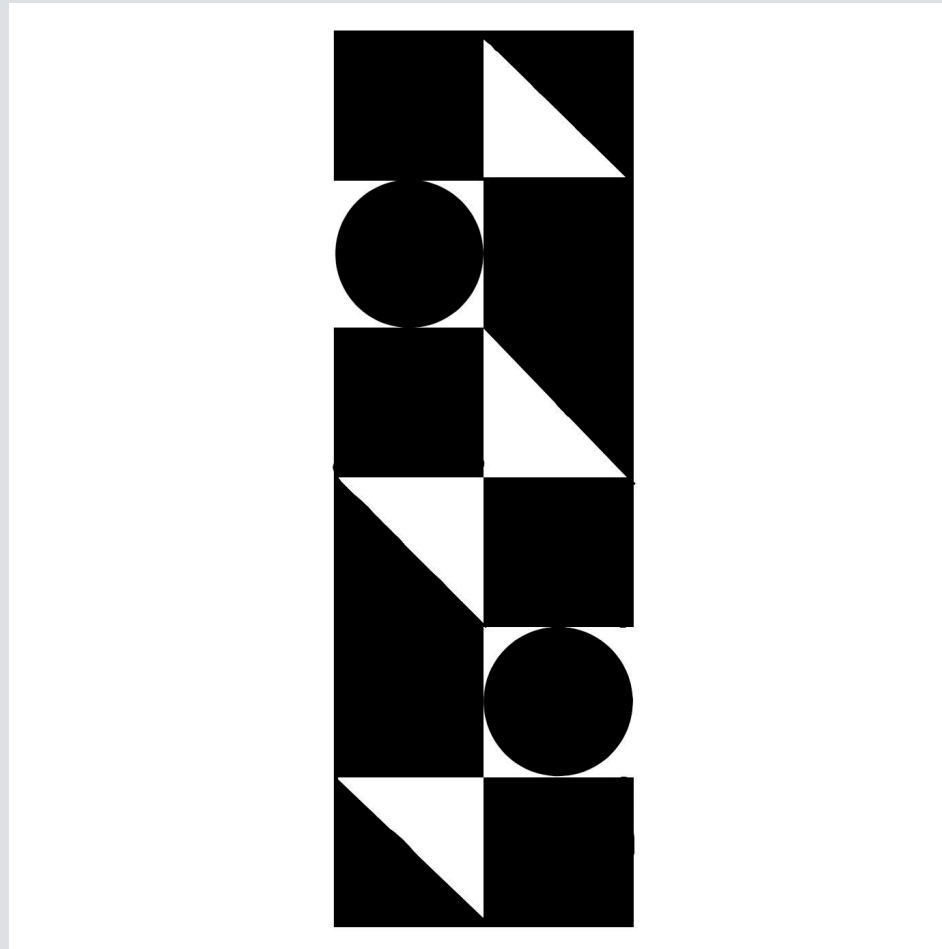
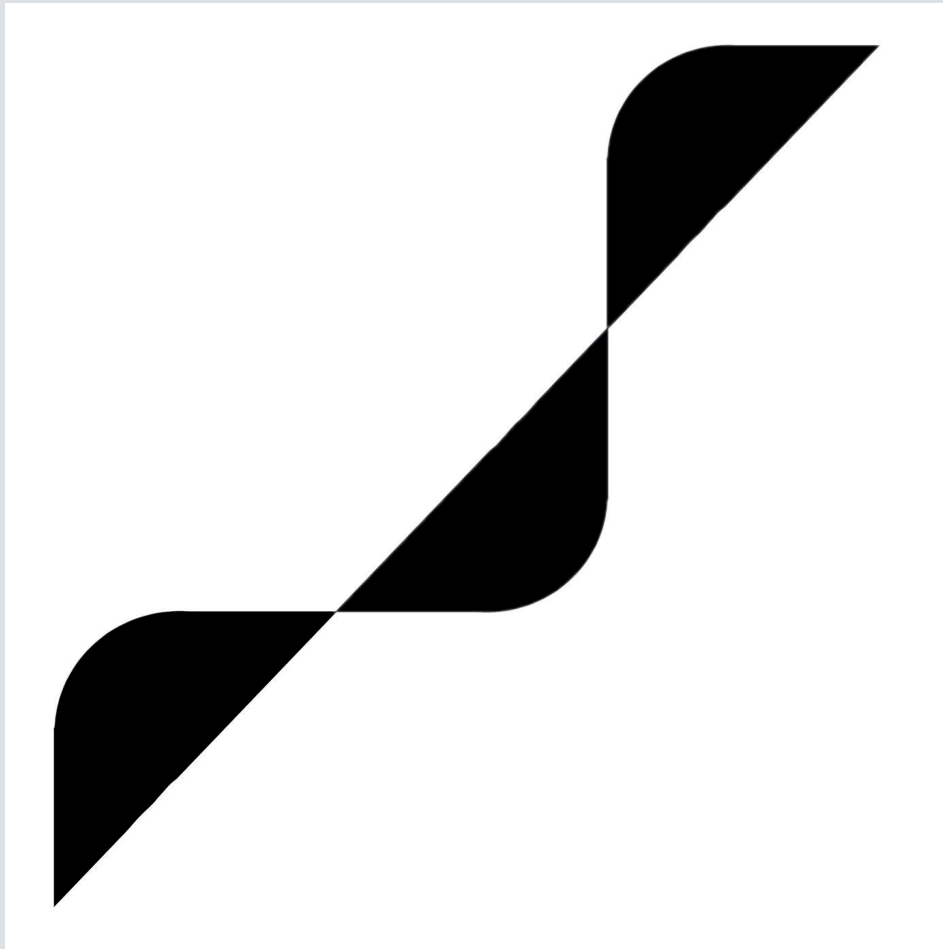

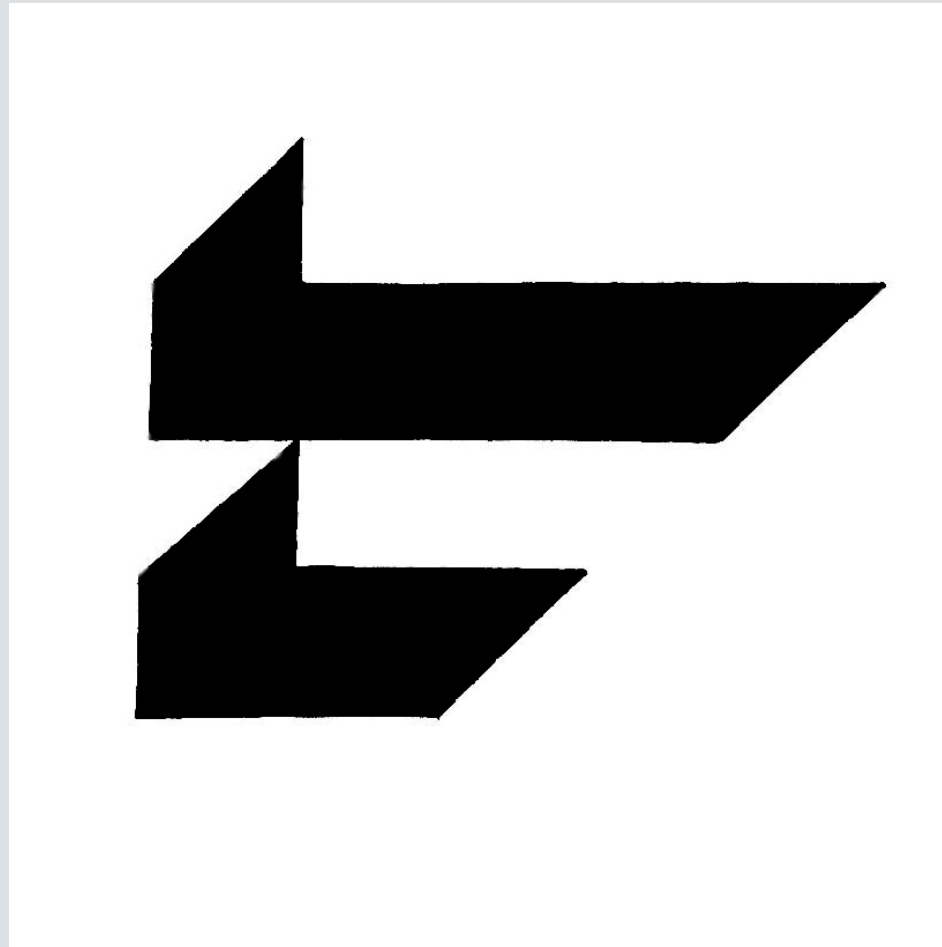
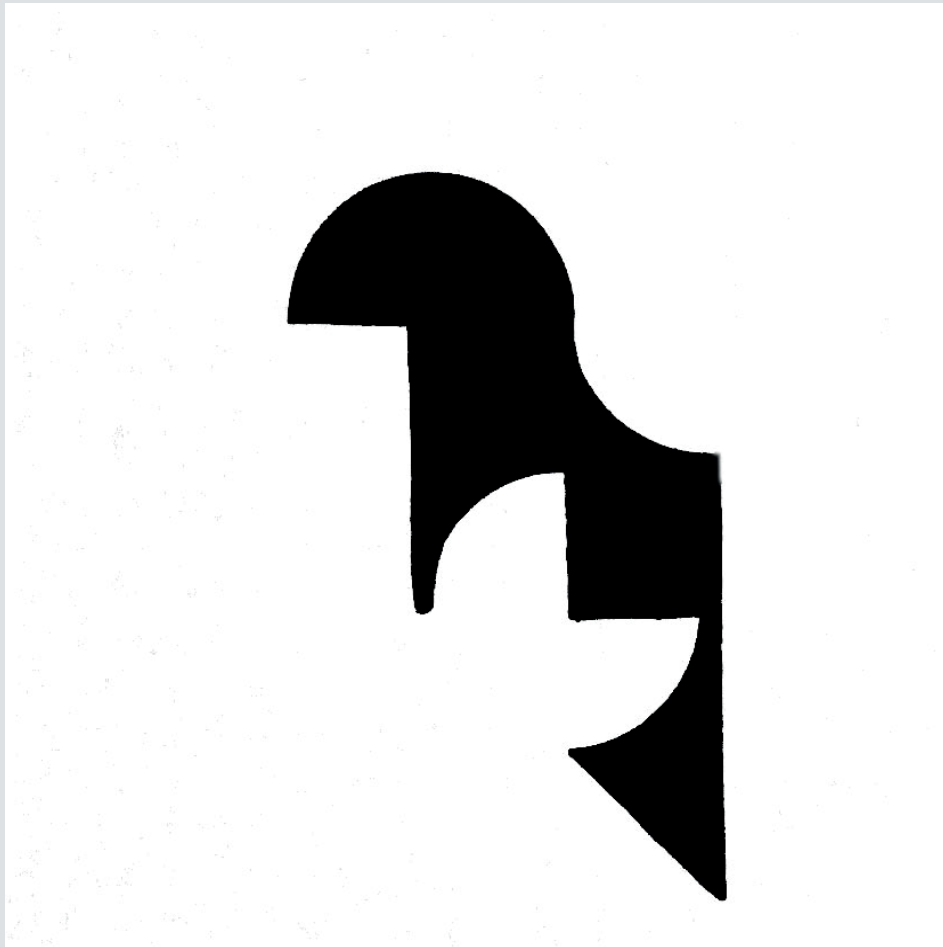

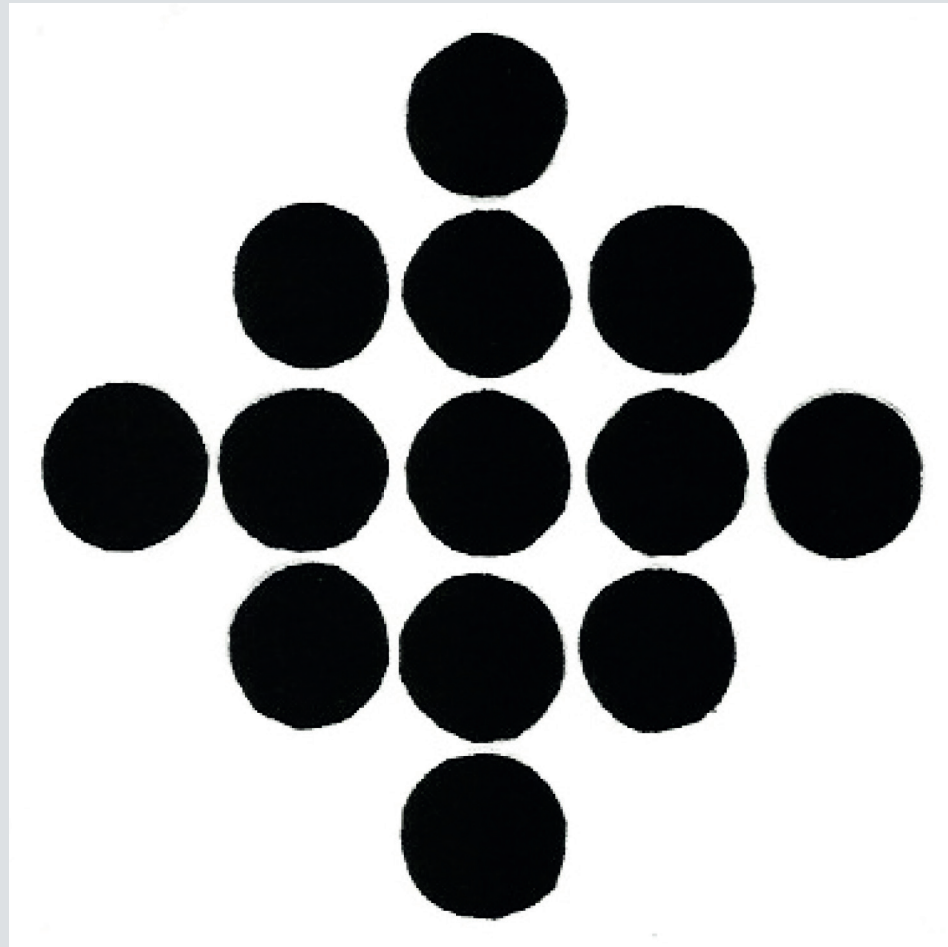
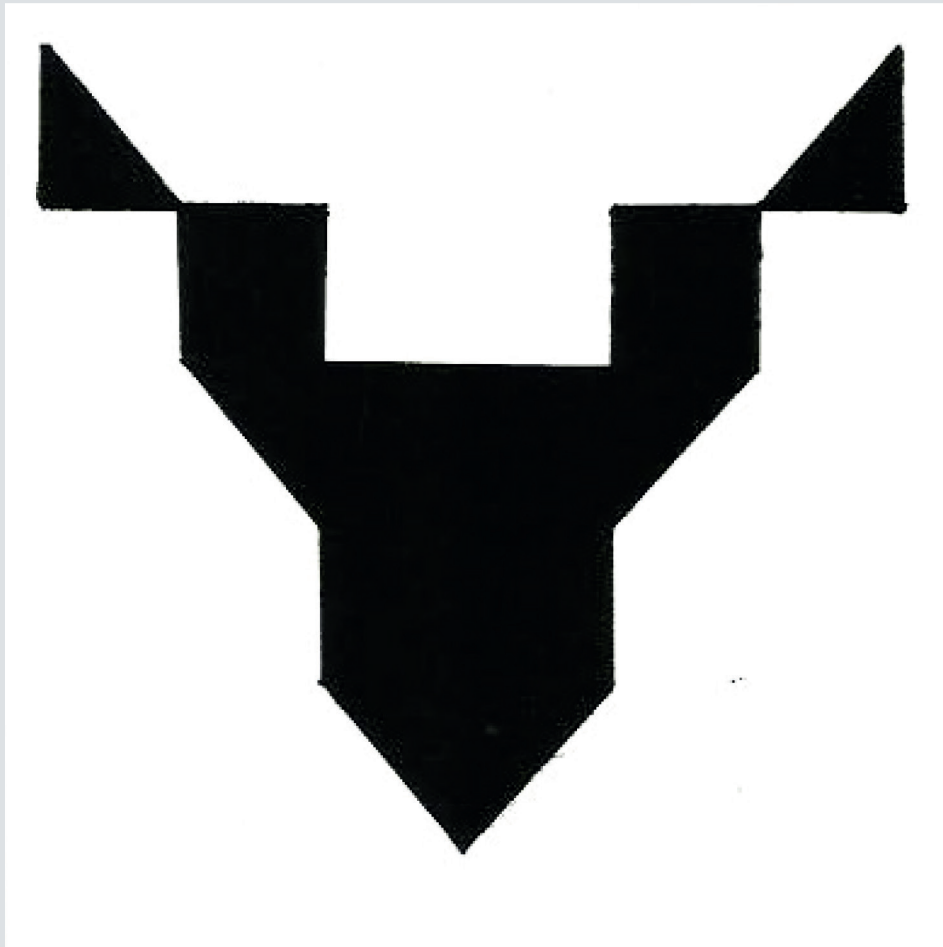

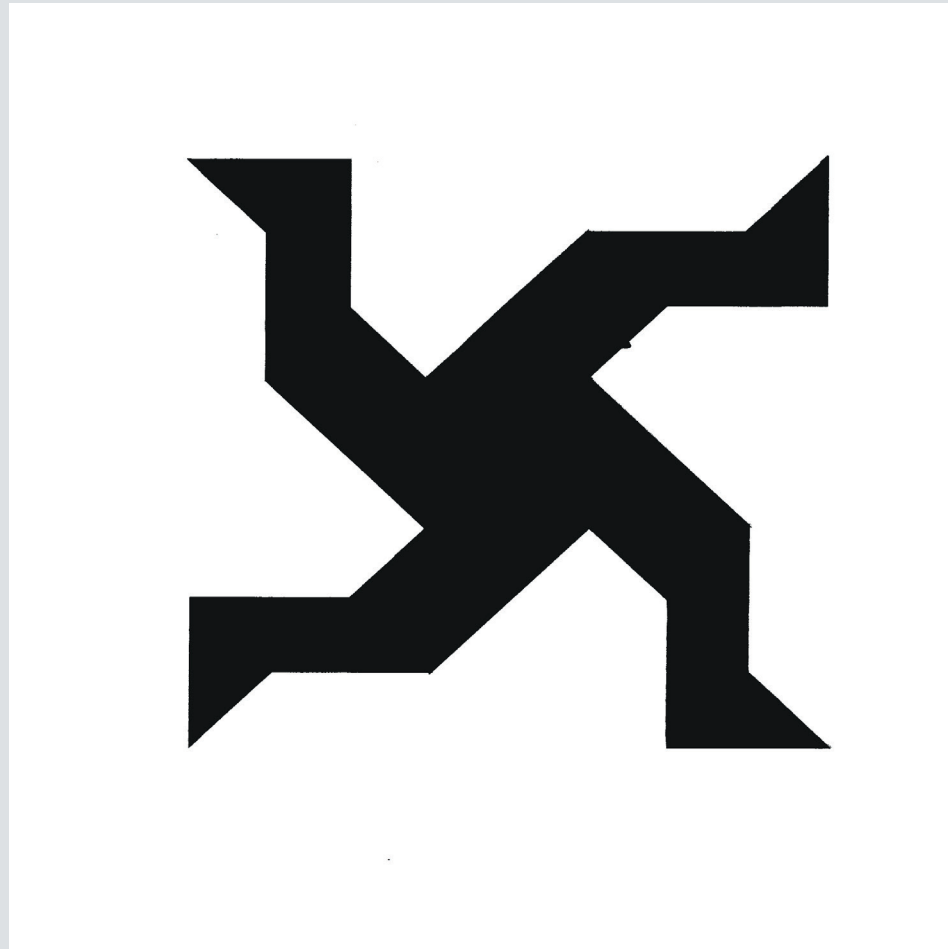
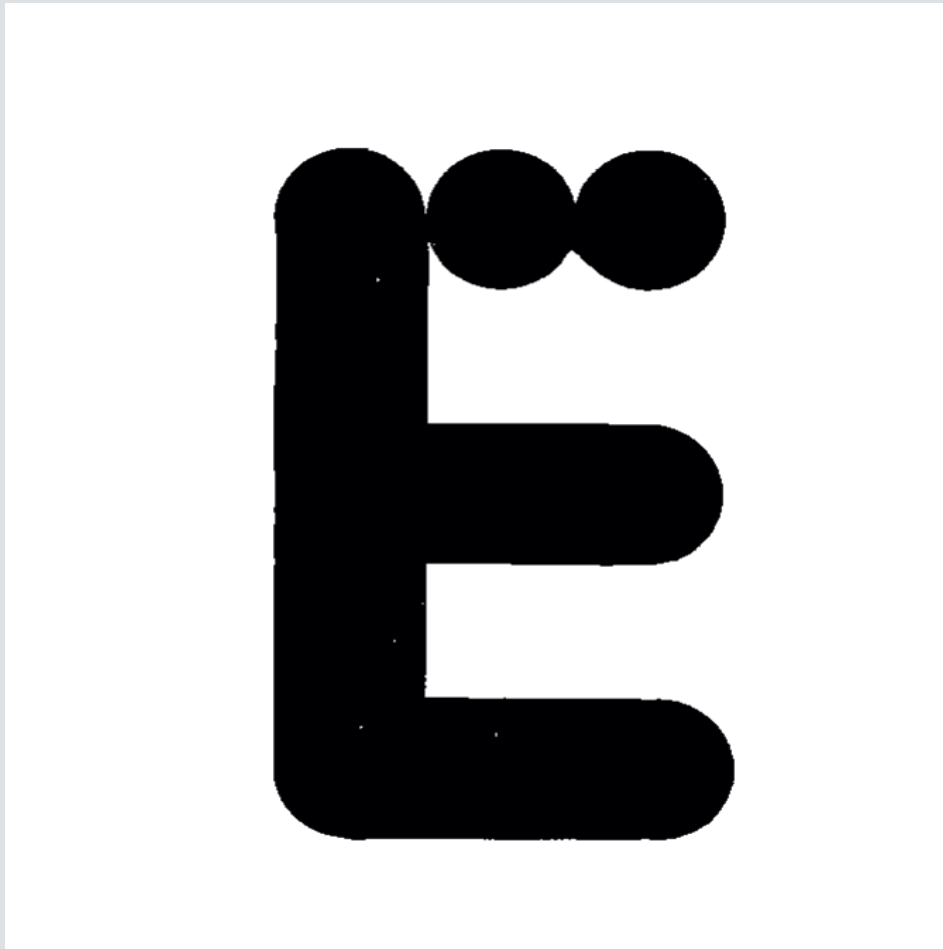

GRUNDLAGEN DER GESTALTUNG 3-D

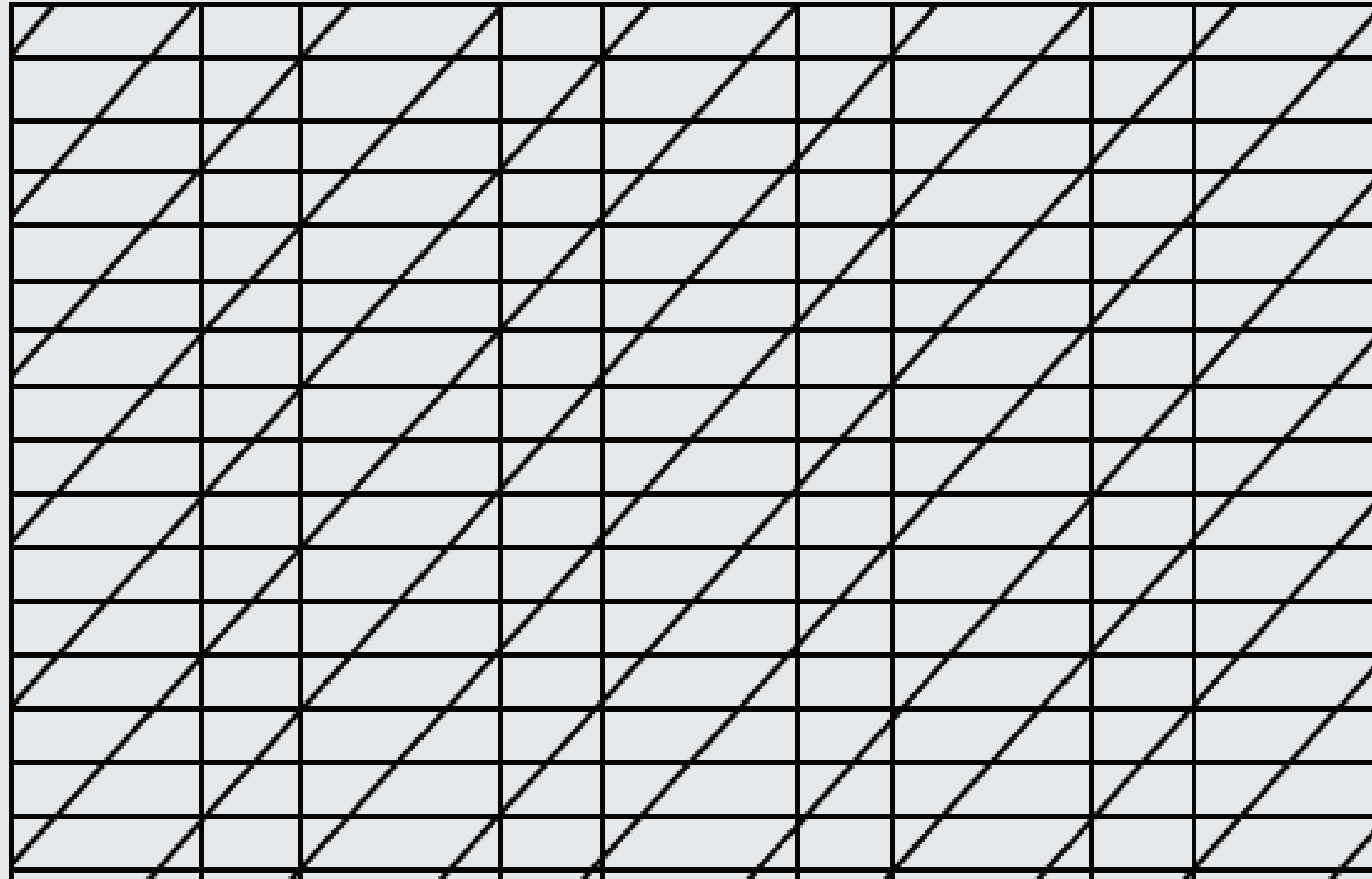





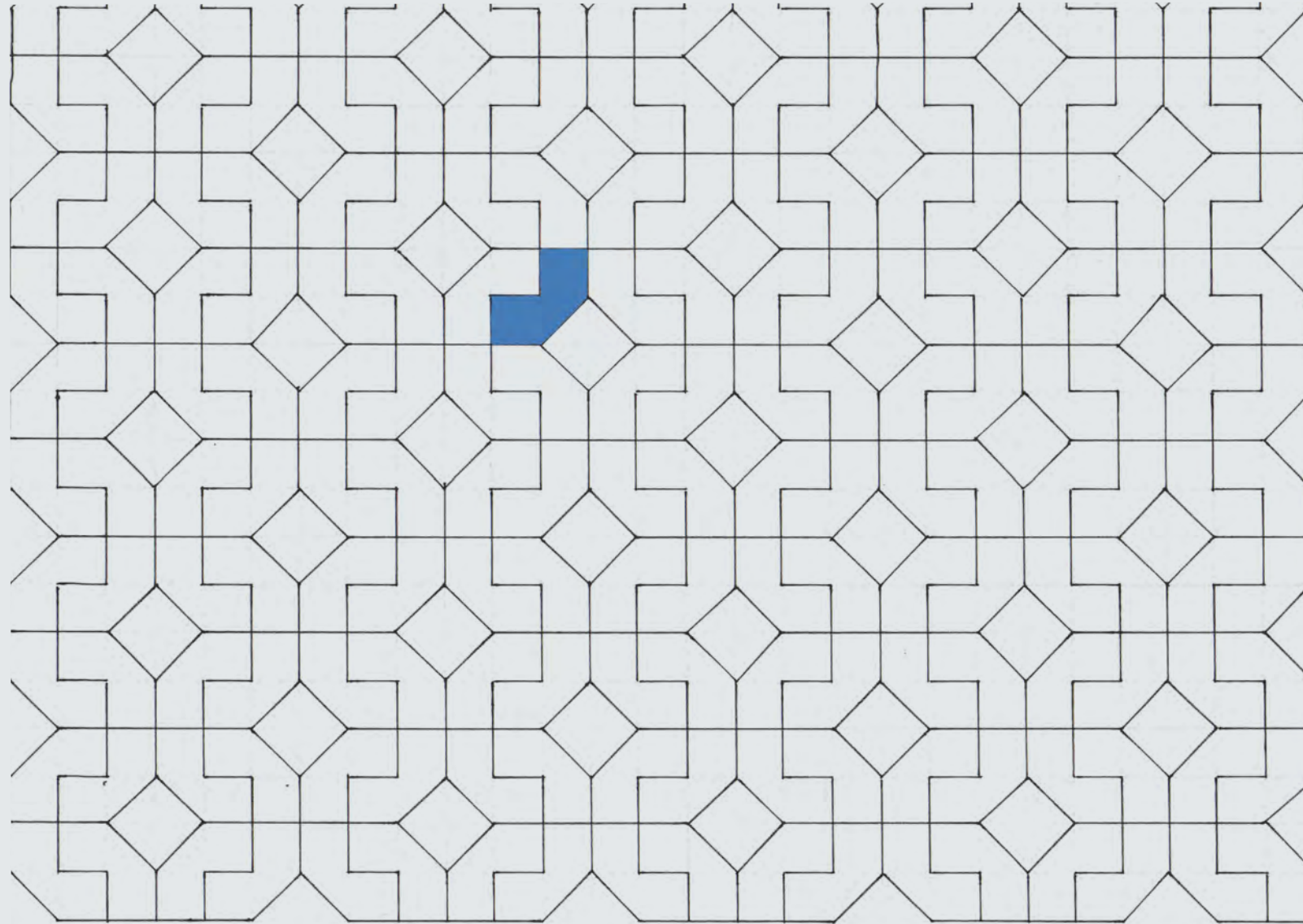

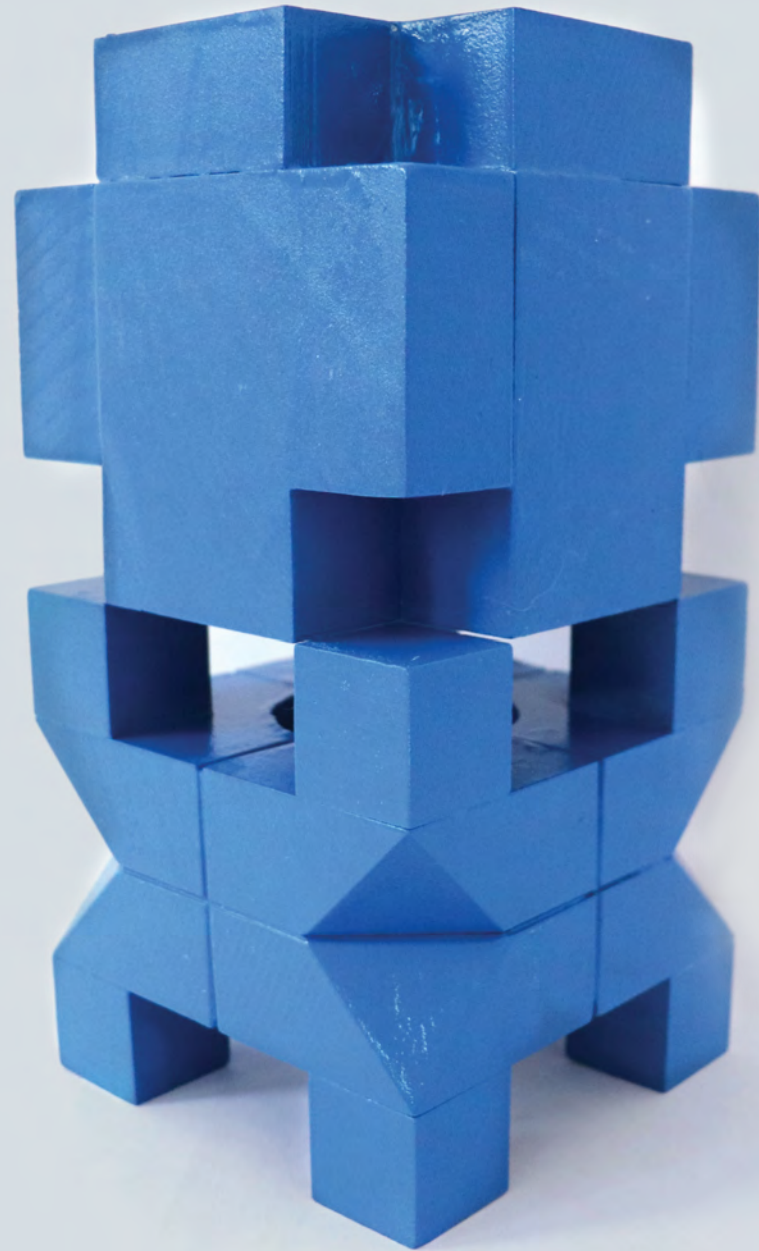



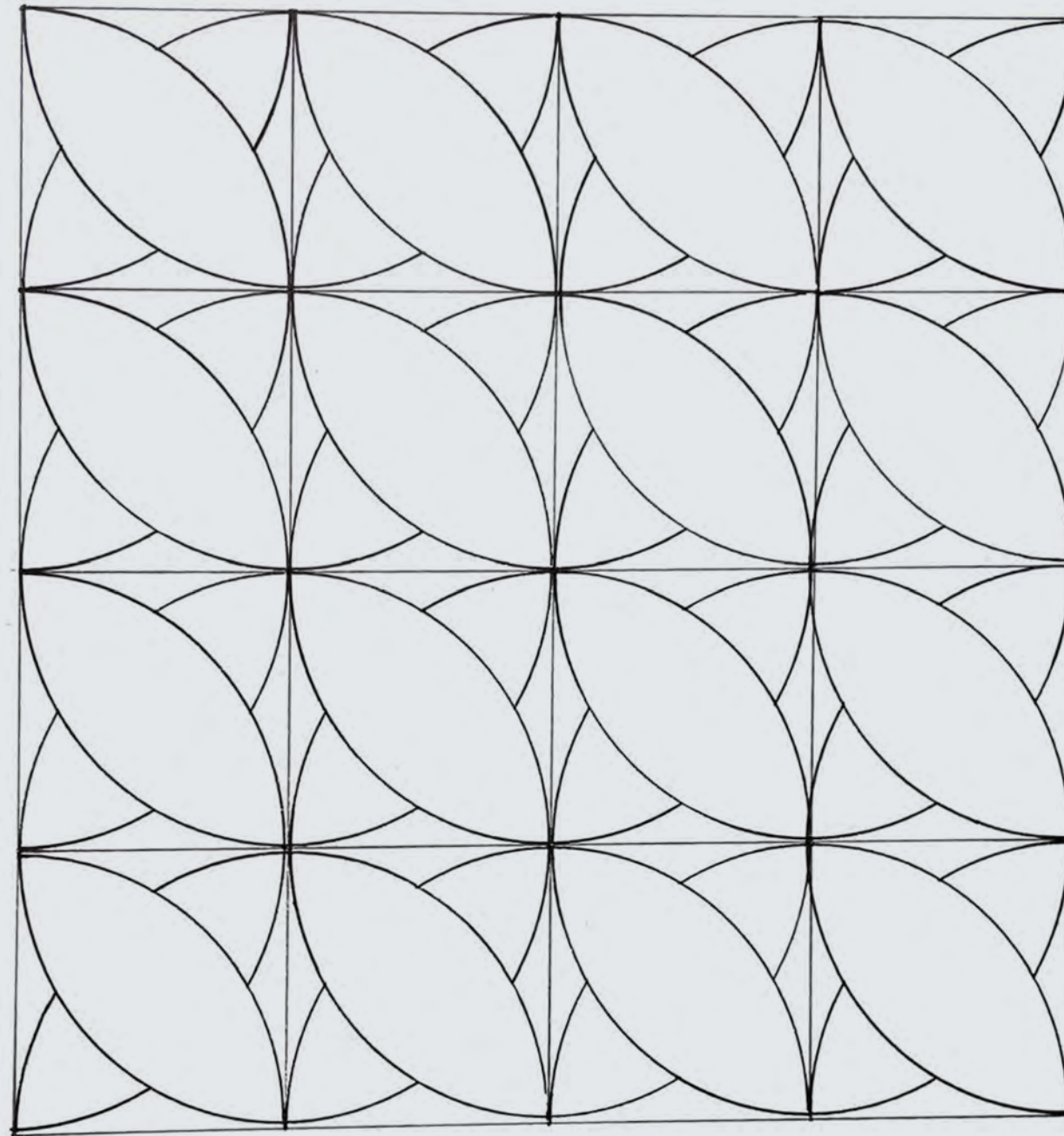





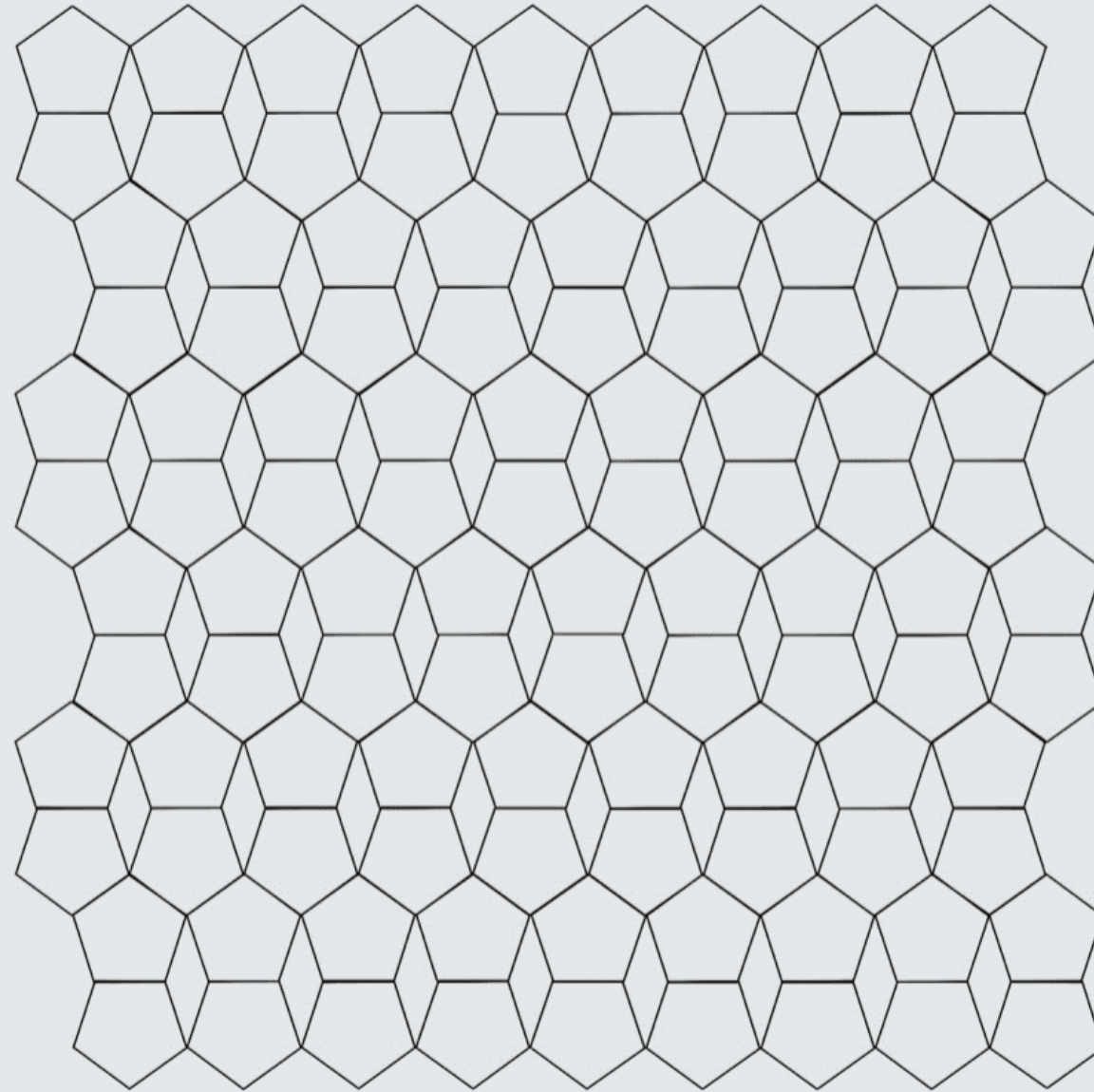





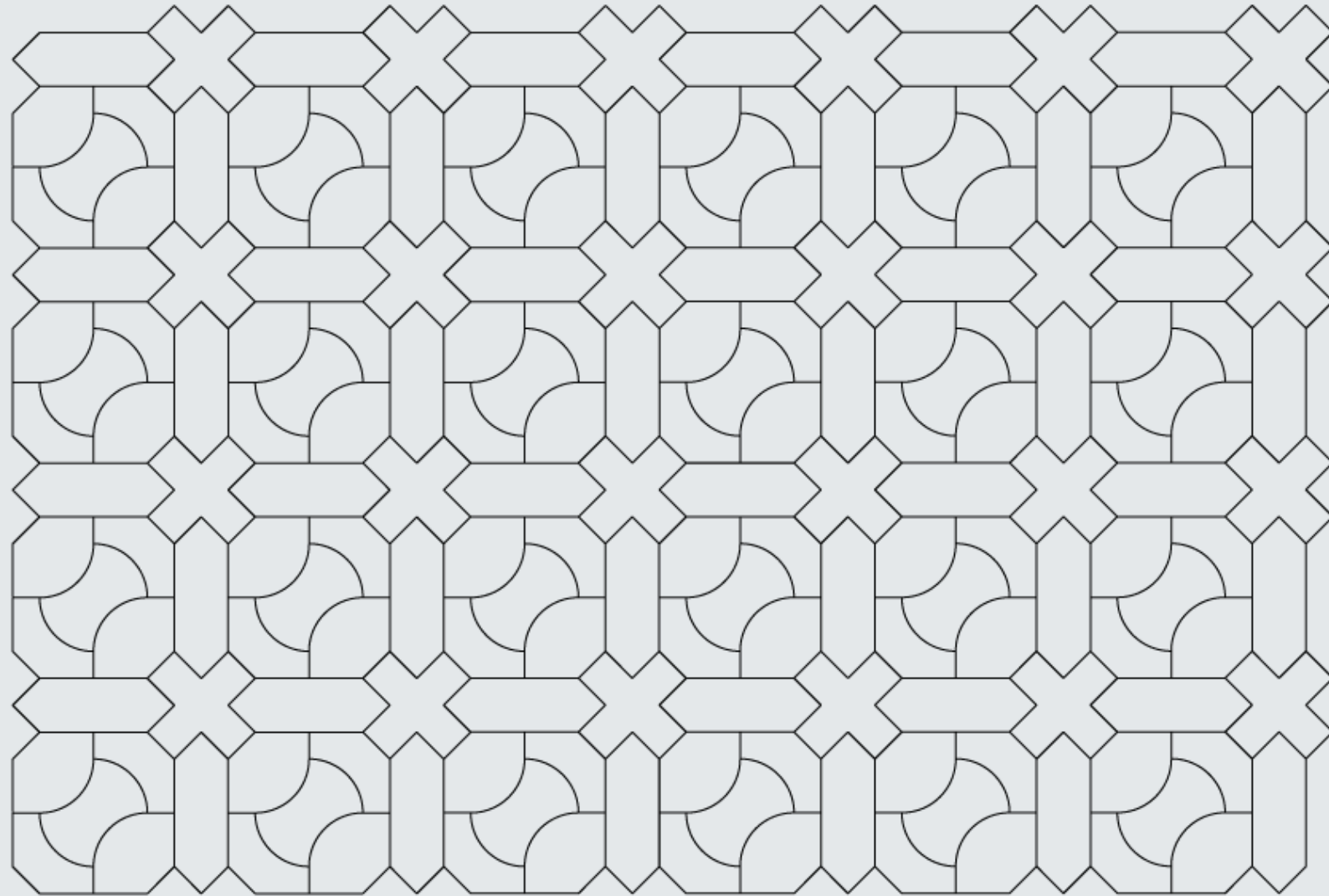

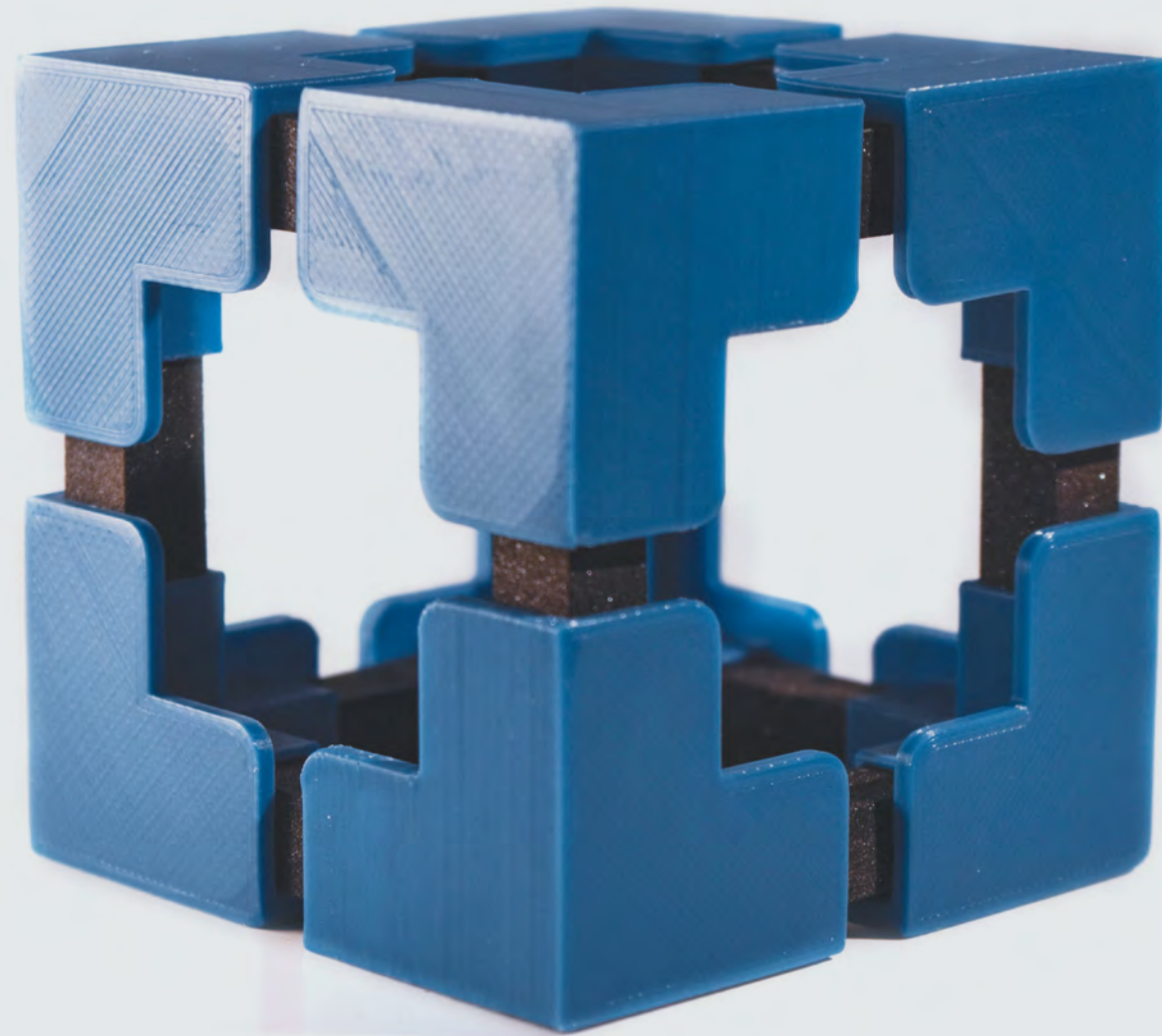



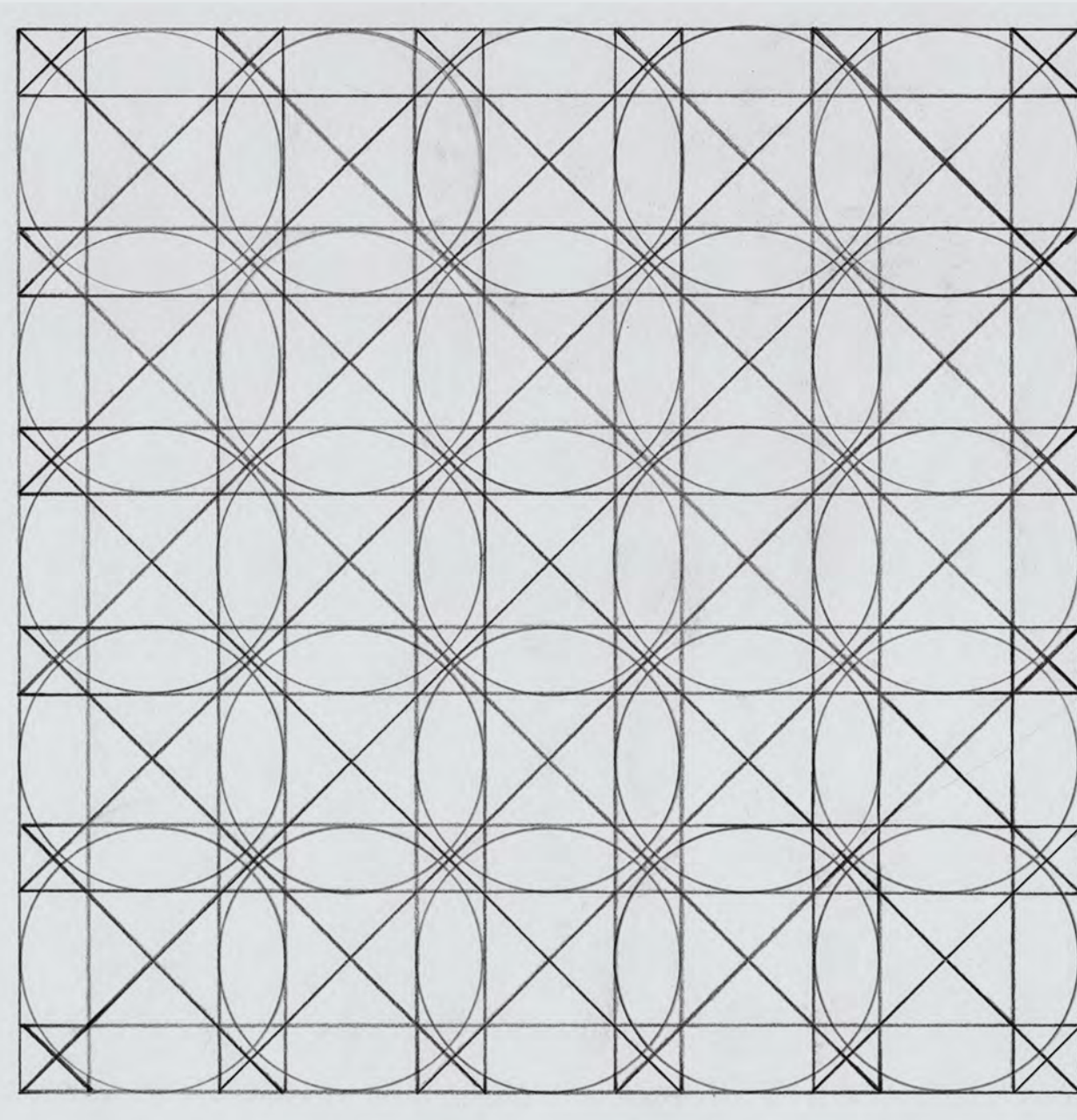

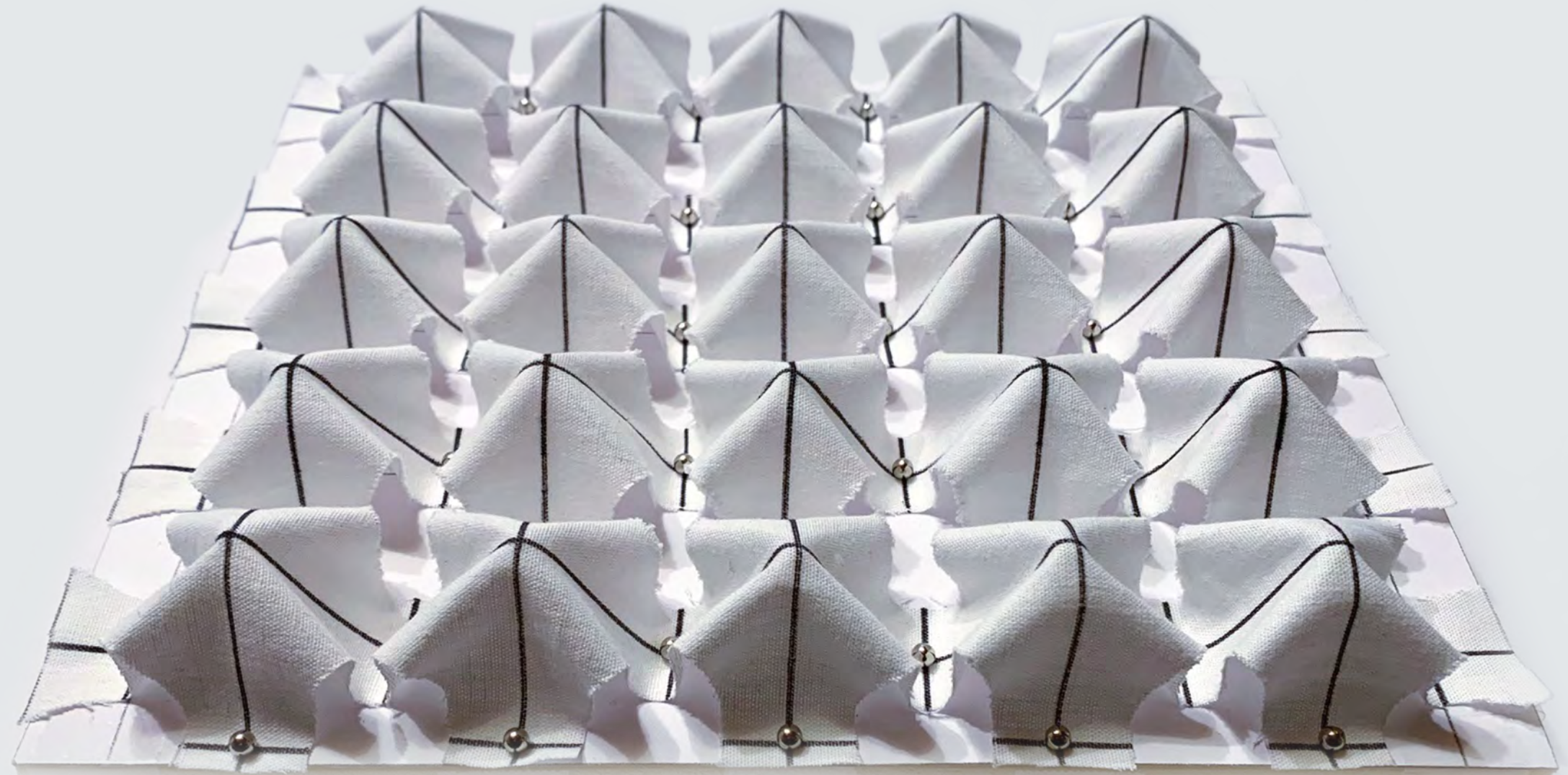

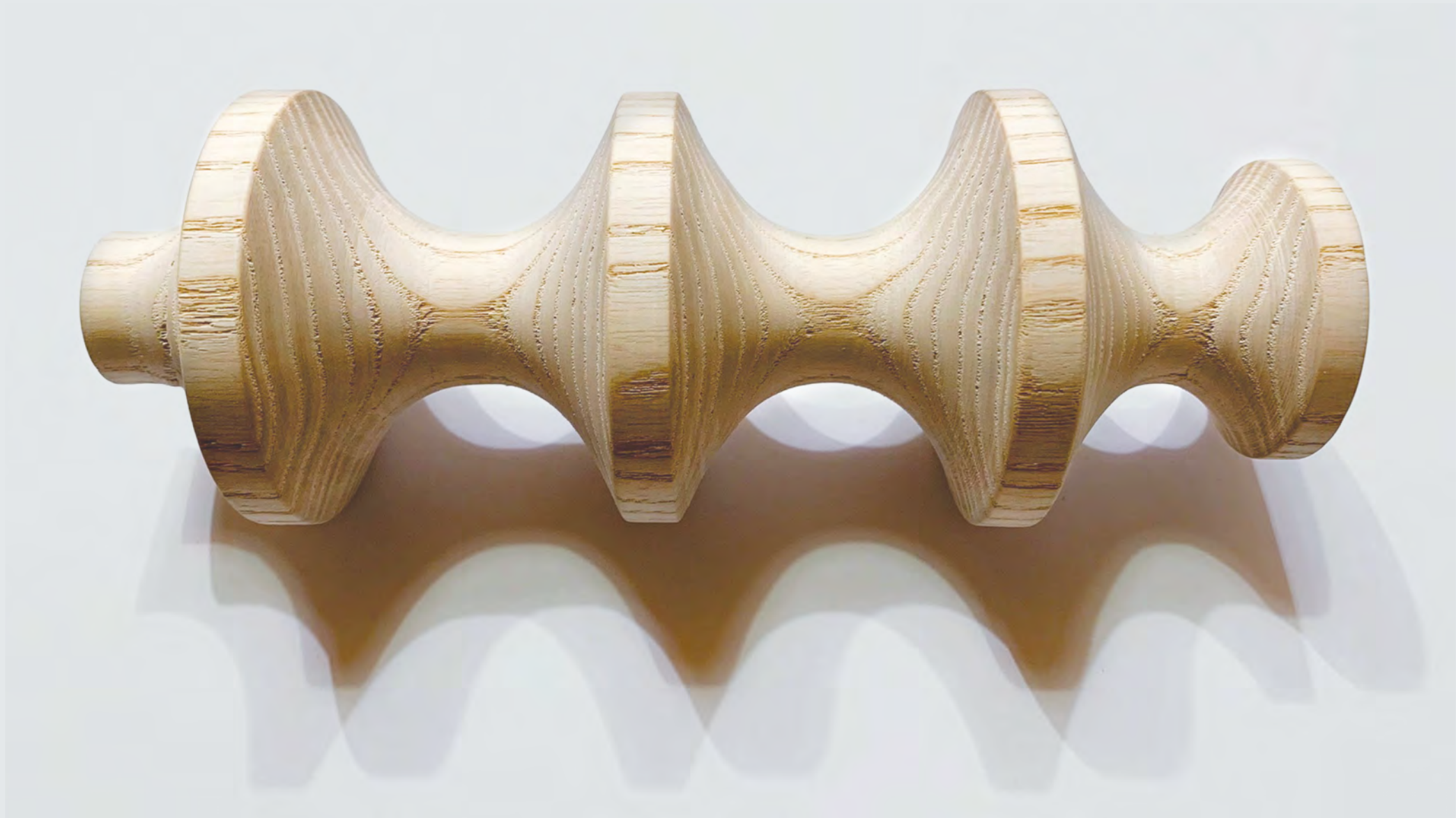

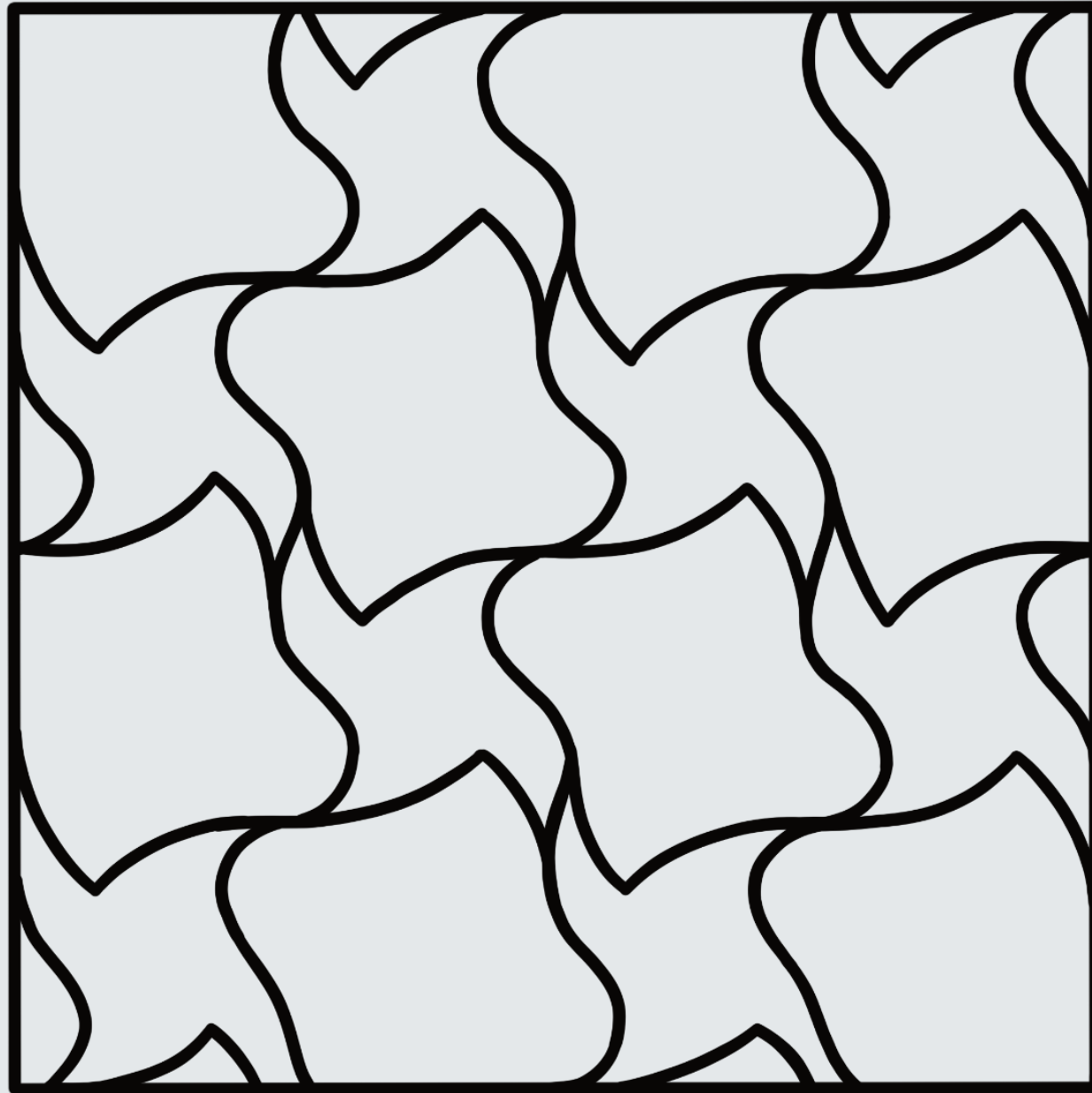





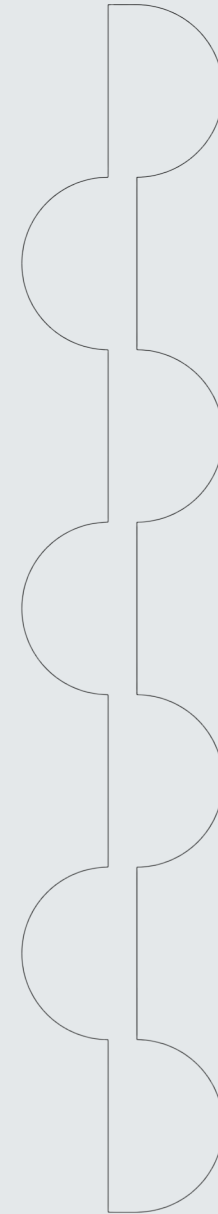
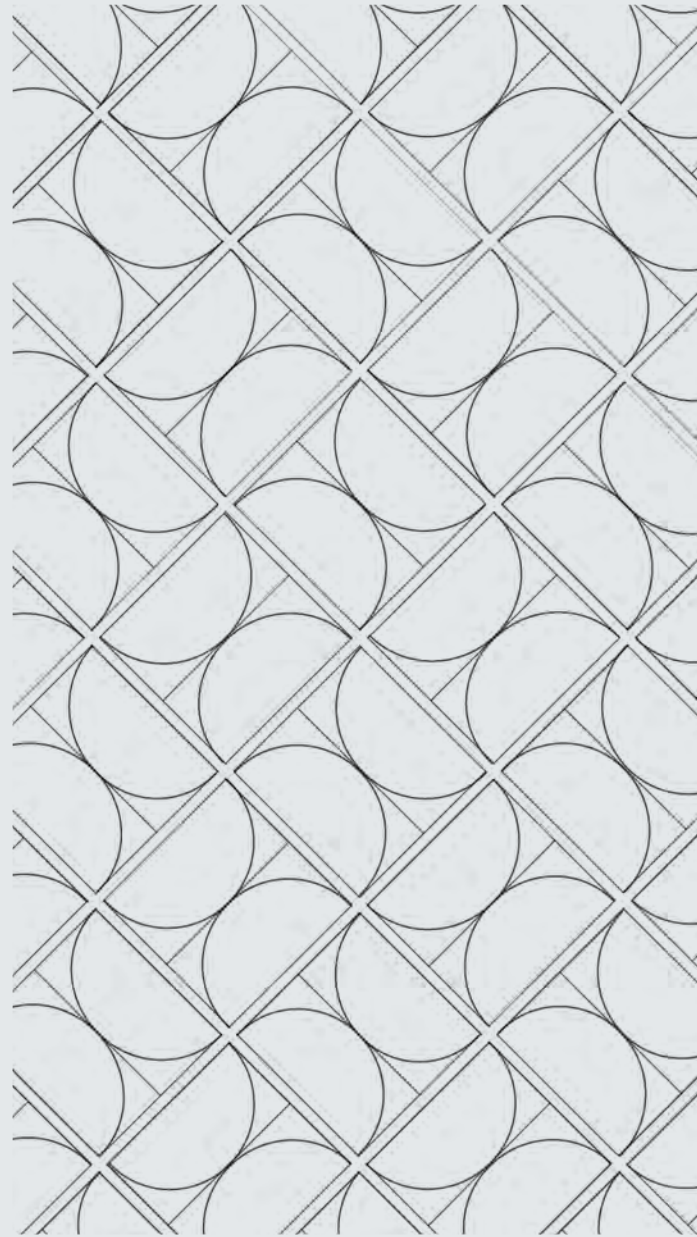





DESIGNPROJEKT DUFT

ROALD AMUNDSEN



REFLEKTIERT

CHARAKTERSTARK

FOKUSSIERT
NEUGIERIG

66
th

KÄMPFERGEIST
EHRGEIZIG

ZIELSTREBIG

DISTANCE
BLIZZARD
FREEDOM
TIMELESS
SILENCE
EXPLORE

EDITION 080

EDITION 109

EDITION 064

EDITION 182





PINA BAUSCH



A collage of various images and text on a black background. The central text reads "impuls." in a white, lowercase, sans-serif font. Surrounding it are several smaller images: a close-up of a fly's wing, a person in a dark, form-fitting outfit performing a dance move, a glowing red DNA helix, a perspective view of a hallway with white walls and a dark floor, a close-up of a textured, brown, crystalline substance, a slice of orange, a cluster of red flowers, a piece of crumpled white paper, a piece of yellow corrugated cardboard, a red square, a dark grey square, a white square, a close-up of hands, and a person in a red dress embracing another person. The text "sehn sucht" is positioned above the DNA helix, "aus druck" is to the right of the orange slice, "e motion en" is above the person in the red dress, and "kon t rast" is below the central text. A quote in German is placed below the dancer: „Mich interessiert nicht, wie die Menschen sich bewegen, sondern was sie bewegt.“

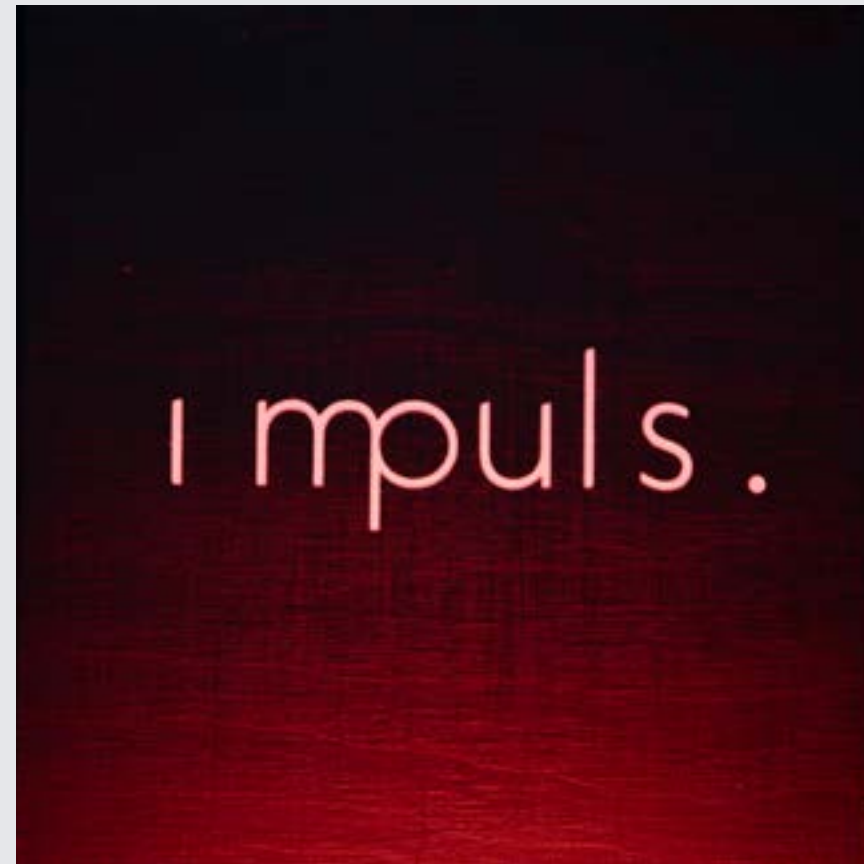

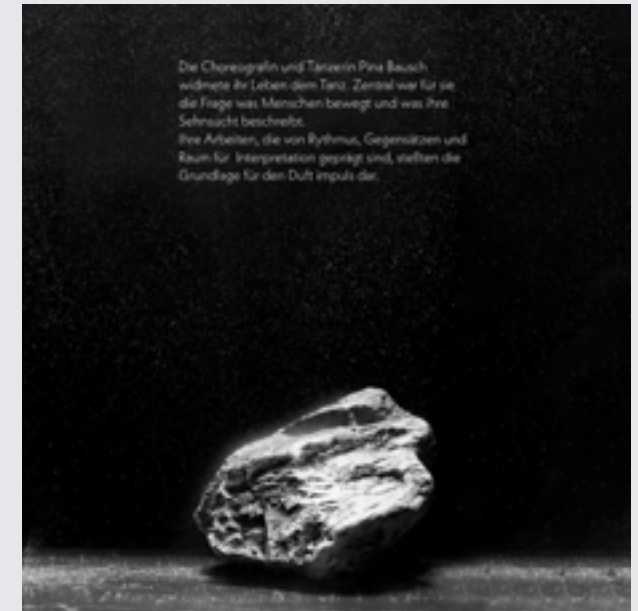
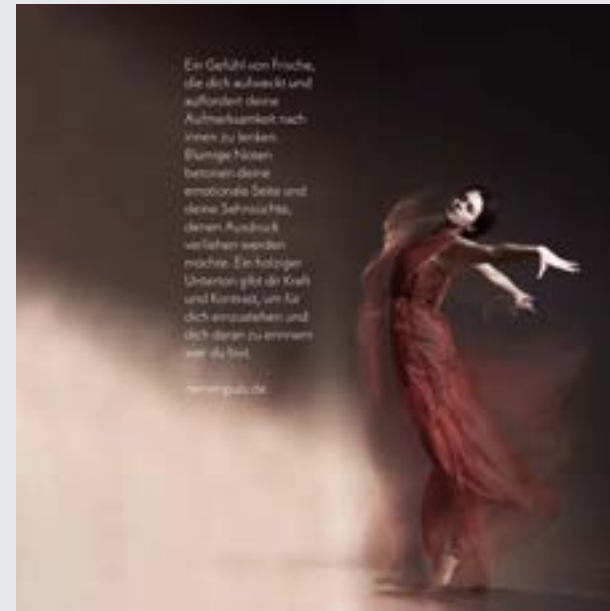





ZINEDINE ZIDANE

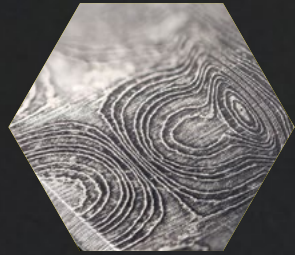

αΖΙΔ

KRAFT



ELEGANZ



AGILITÄT







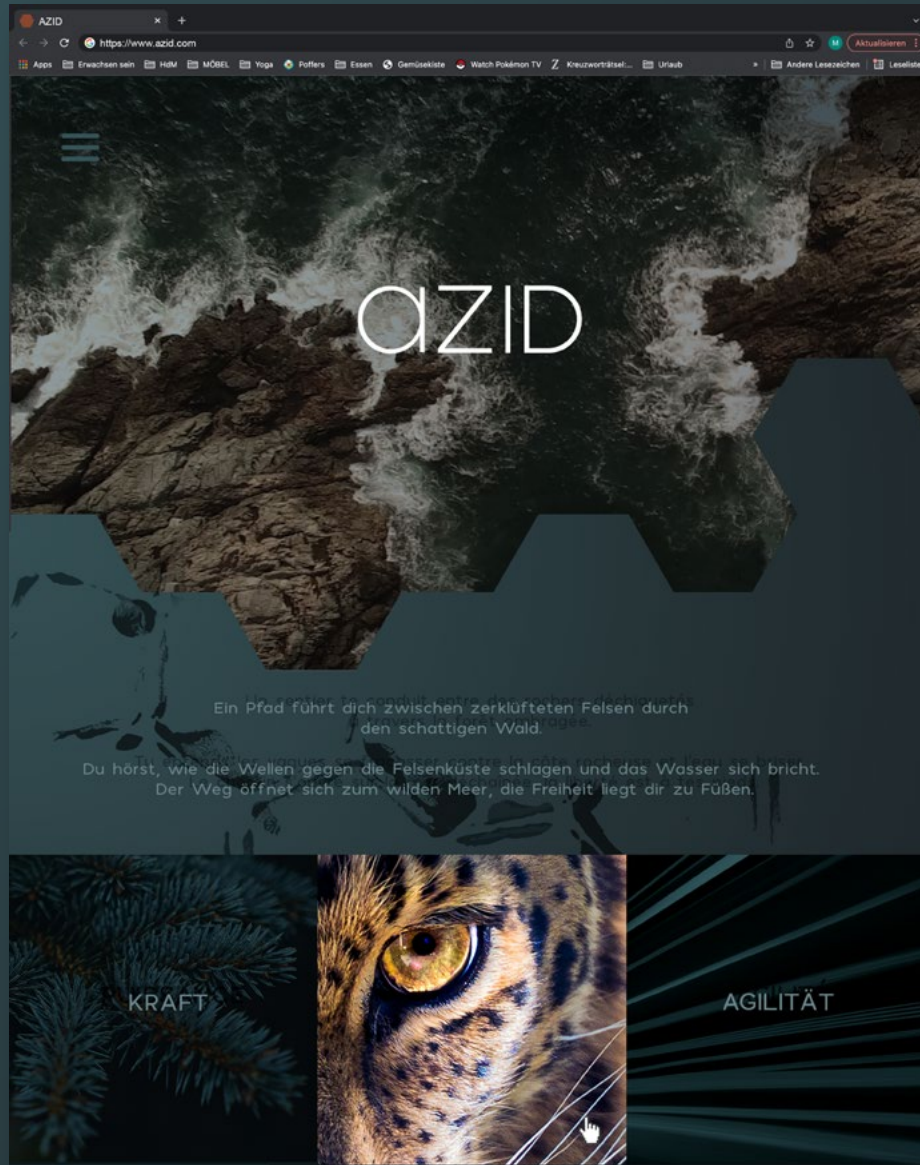

ZAHA HADID

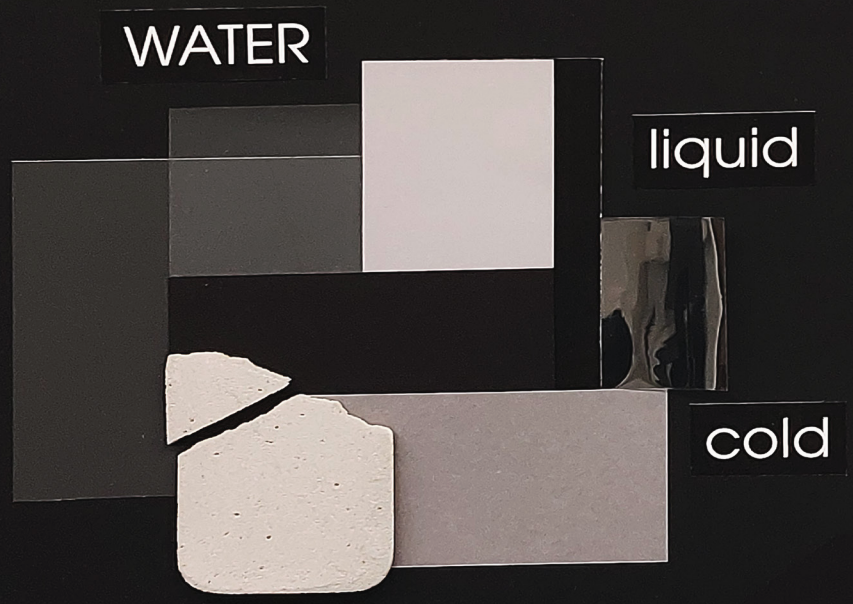
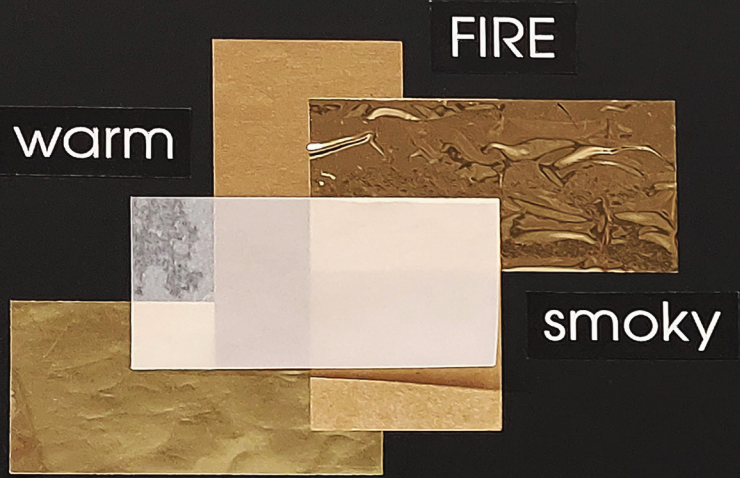



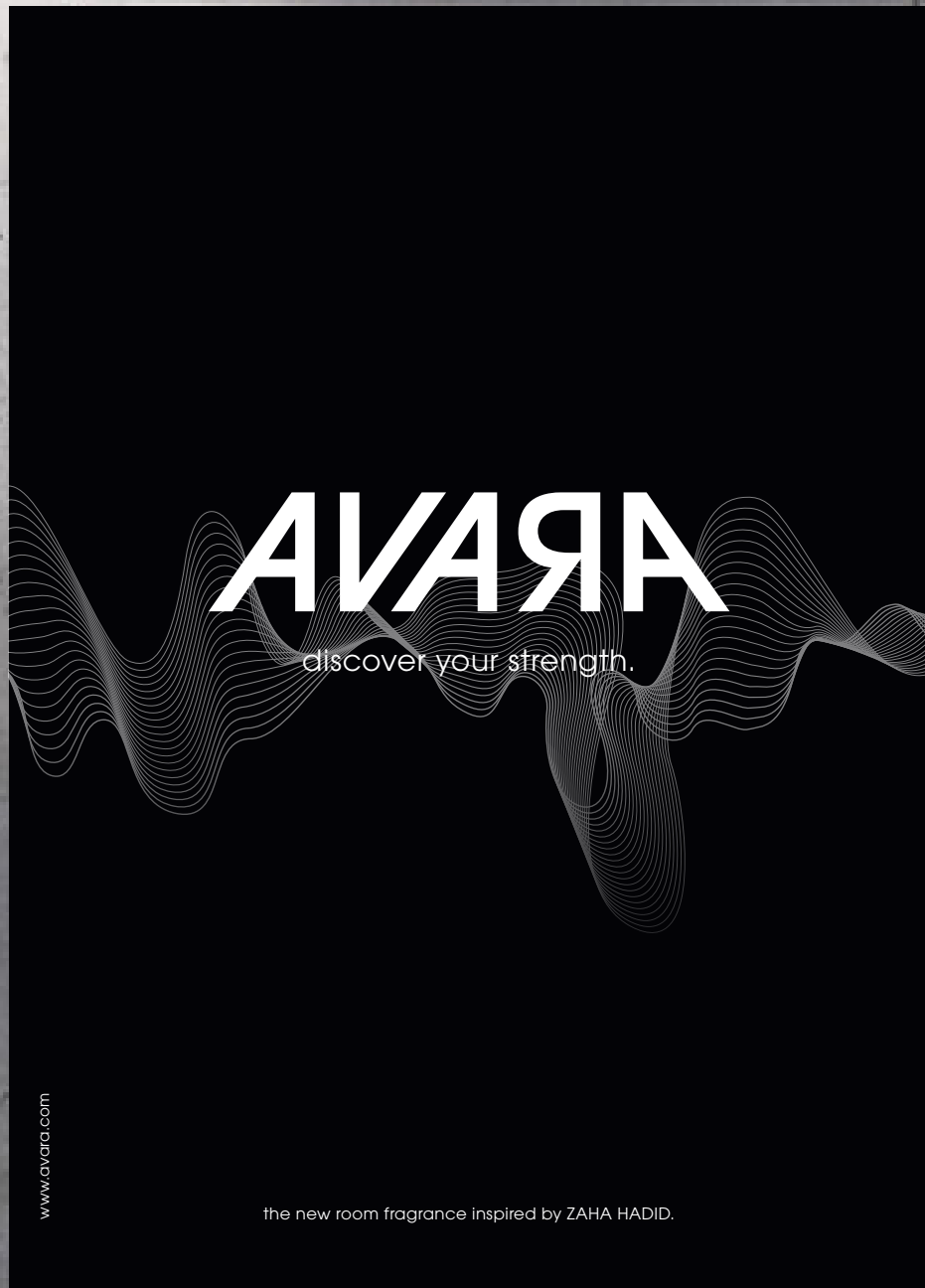

AVARA
discover your strength.

www.avara.com

the new room fragrance inspired by ZAHA HADID.

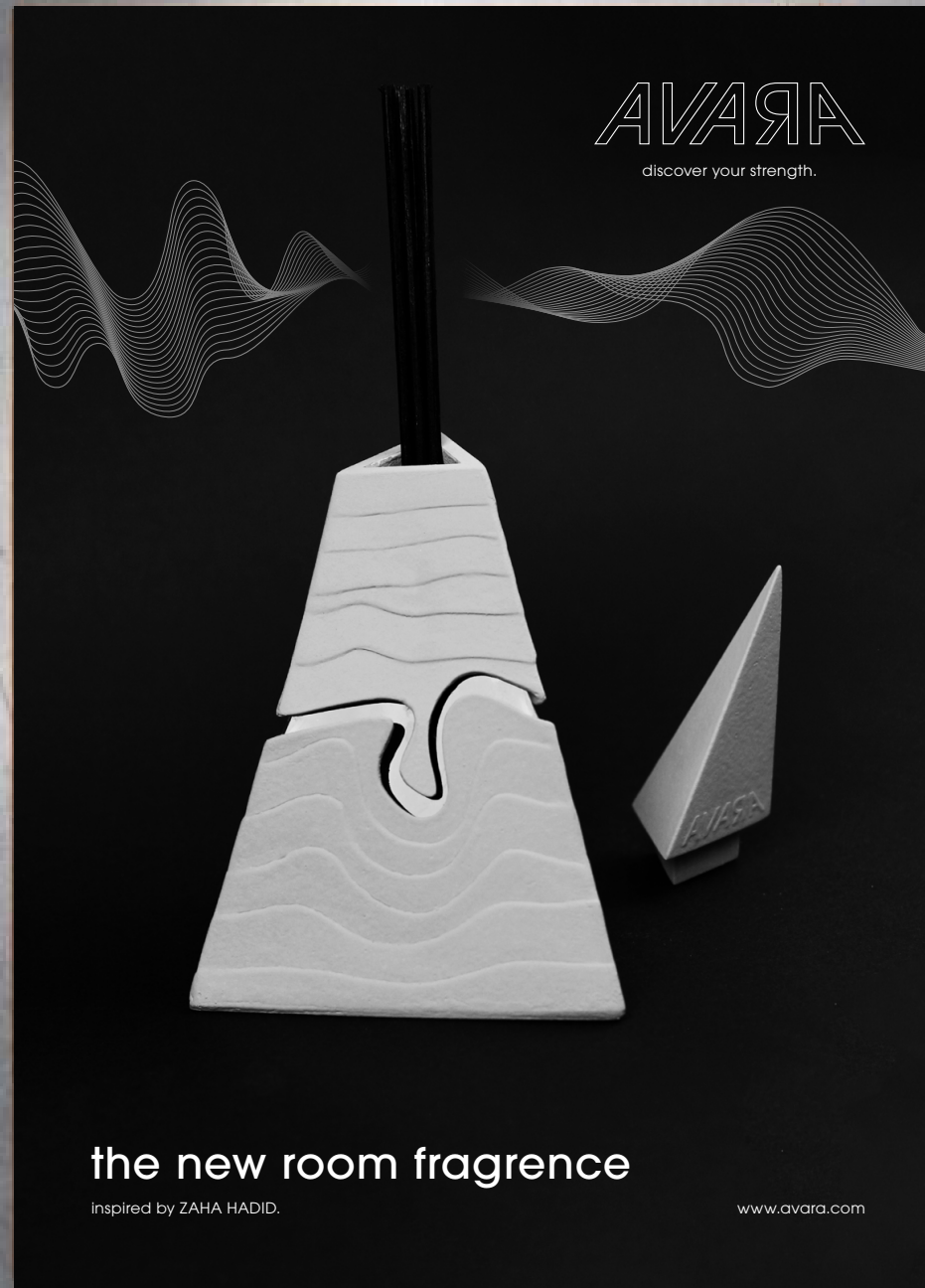

AVARA
discover your strength.

the new room fragrance
inspired by ZAHA HADID.

www.avara.com

PEDRO ALMODOVAR

DESIGNPROJEKT DUFT

PEDRO ALMODÓVAR



VUERVAR

seducción

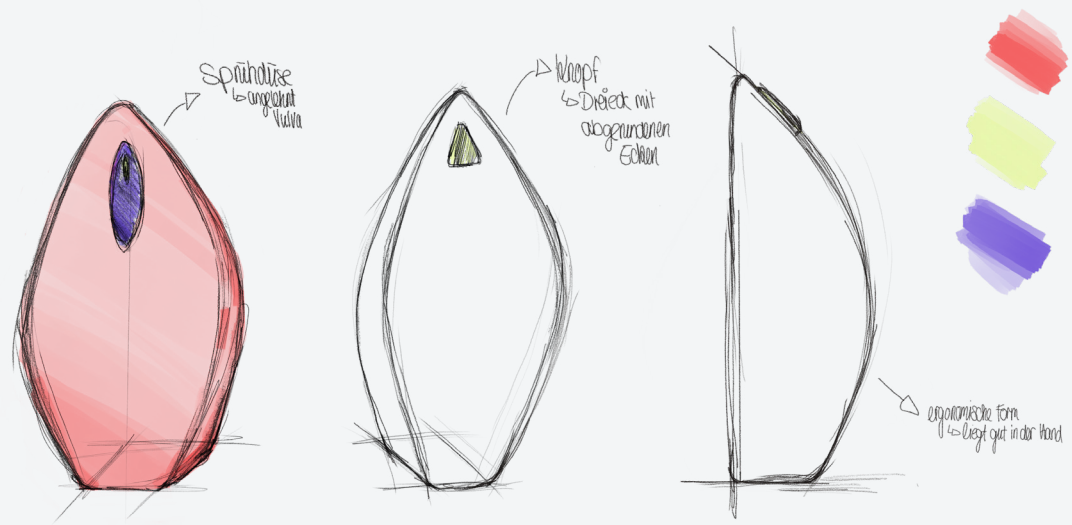

VUERVAR

seducción



„Ich glaube, dass Frauen eine besondere Fähigkeit haben, die Welt zu korrigieren.“

www.vuervar.de

Analoge Medien





Digitale Medien



TADAO ANDO

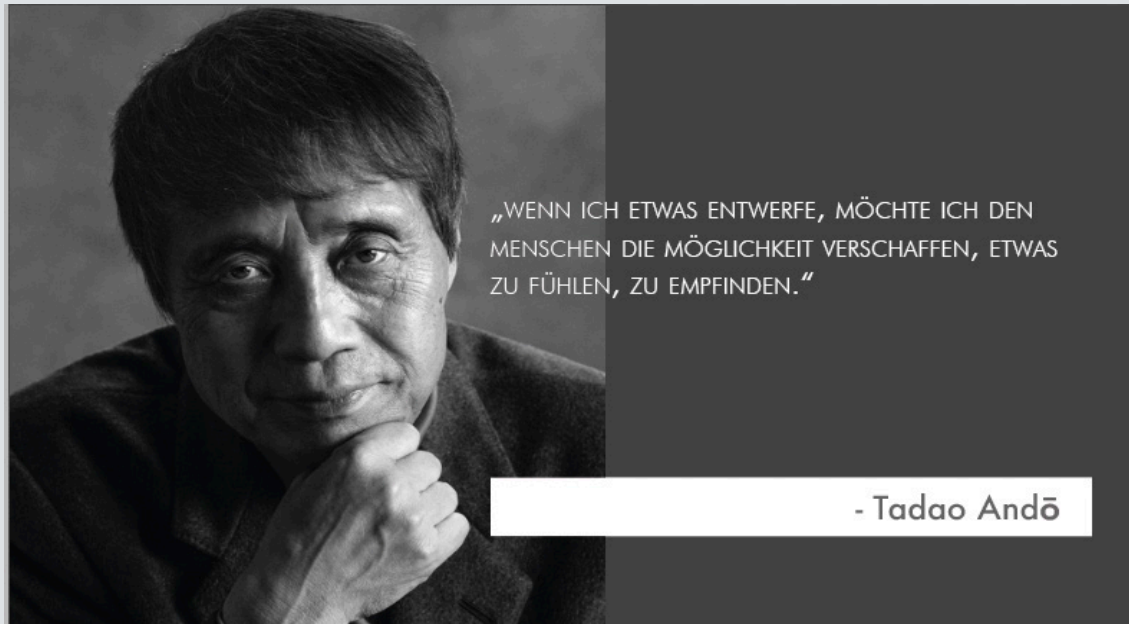





TADAO ANDO

„Wenn ich entwerfe, möchte ich den Menschen die Möglichkeit verschaffen, etwas zu fühlen, zu empfinden.“





DER DUFT

Regen prasselt auf rauem Beton, Petrichor steigt in die Luft. Wie frühlinghaftes Erwachen mischt sich Kirschblütenduft dazu. Schmale Lichtschlitze lassen frischen Morgenwind durch Wände aus Beton wandern. Kirschblüten tanzen mit Zitronenverbene. Ruhig wiegt sich eine Zeder in der Brise und in der Nähe kocht jemand Reis.

DER DIFFUSER

Der Diffuser aus Beton vaporisiert einen einzigartigen Duft, der zum Verweilen und in sich Kehren anregt. Das schlichte Design ist inspiriert von Tadao Andos Architektur. Das integrierte Licht lässt den Diffuser als Stimmungsleuchte fungieren und unterstützt die Entspannung. Ob einzeln oder in seiner Verpackung aus japanischer Zeder, ist der Diffuser ein zeitloser Einrichtungsgegenstand der Luxusklasse.



KONTAKT

+49 172 4399283
SCENT@KAORI.COM
WWW.KAORI.COM

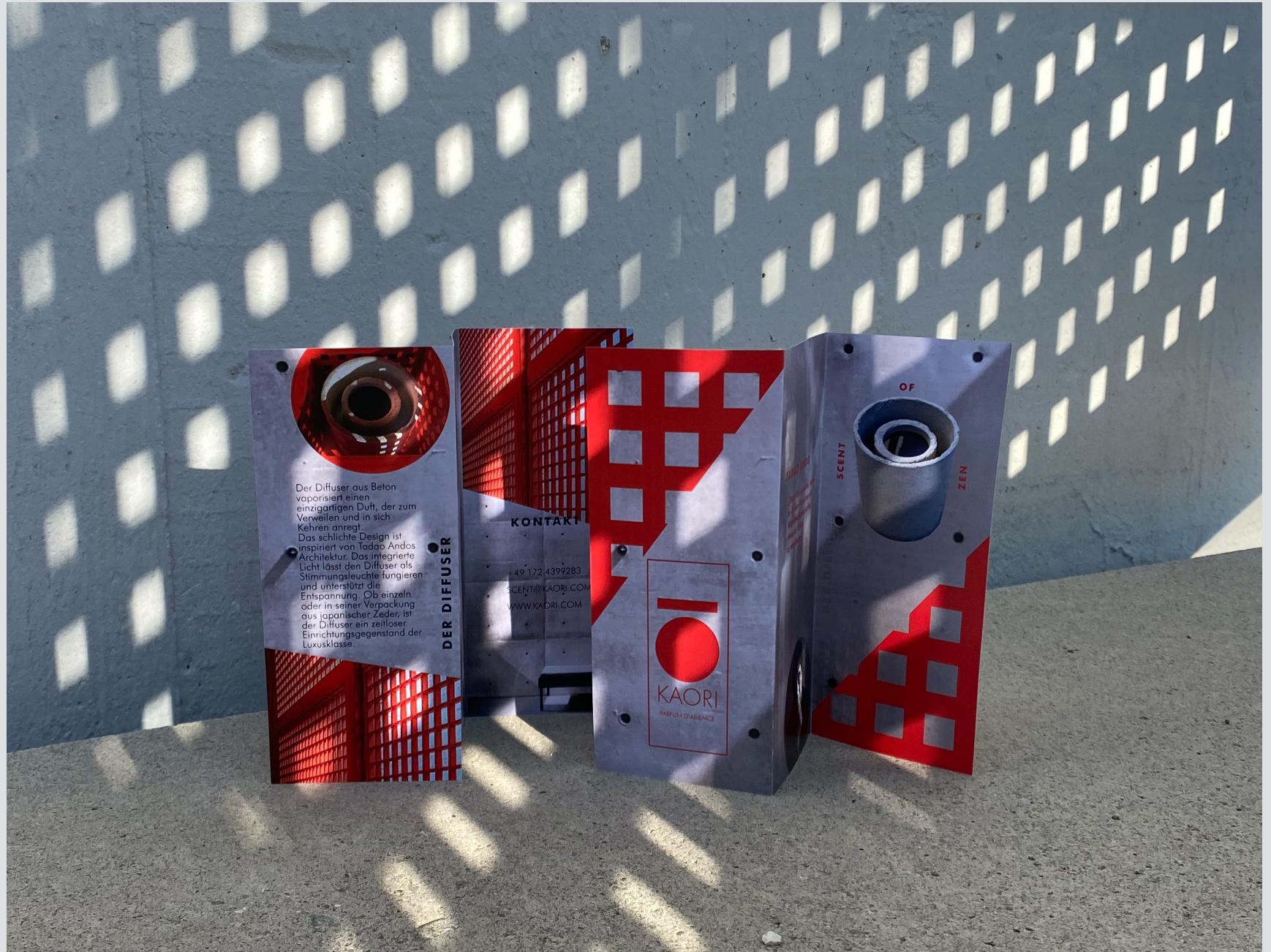

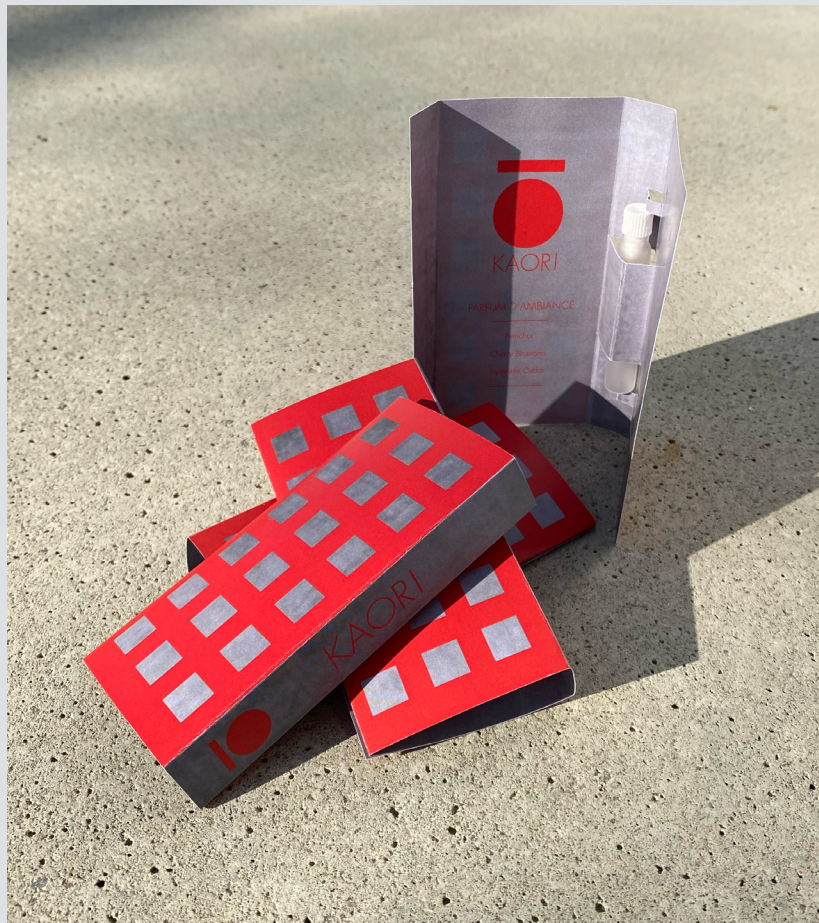
JEANNE D'ARC



d'arc





d'arc



d'arc

d'arc

"Go forward bravely.
Fear nothing.
All will be well."

~ Jeanne d'Arc

fragrance

d'arc strolls through the pale purple saffron fields, vineyards in the background. Bells ringing from a distance. Incense. A bee flies by.

d'arc combines the heaviness of red wine with the sweetness of honey.

d'arc is

brave
bold
young
innocent
strong
progressive



fragrance

d'arc strolls through the pale purple saffron fields; vineyards in the background. Bells ringing from a distance. Incense. A bee flies by.

d'arc combines the heaviness of red wine with the sweetness of honey.

d'arc is

brave
bold
young
innocent
strong
progressive

d'arc 143,10 € / 100 ml

add to cart

[contact](#) [services](#) [privacy](#) [terms](#)

OSCAR WILDE



romantisch
individuell

début

charakterstark
extravagant



"I have the simplest tastes.
I am always satisfied with the best."





DESIGNPROJEKT KRAN

KABINE

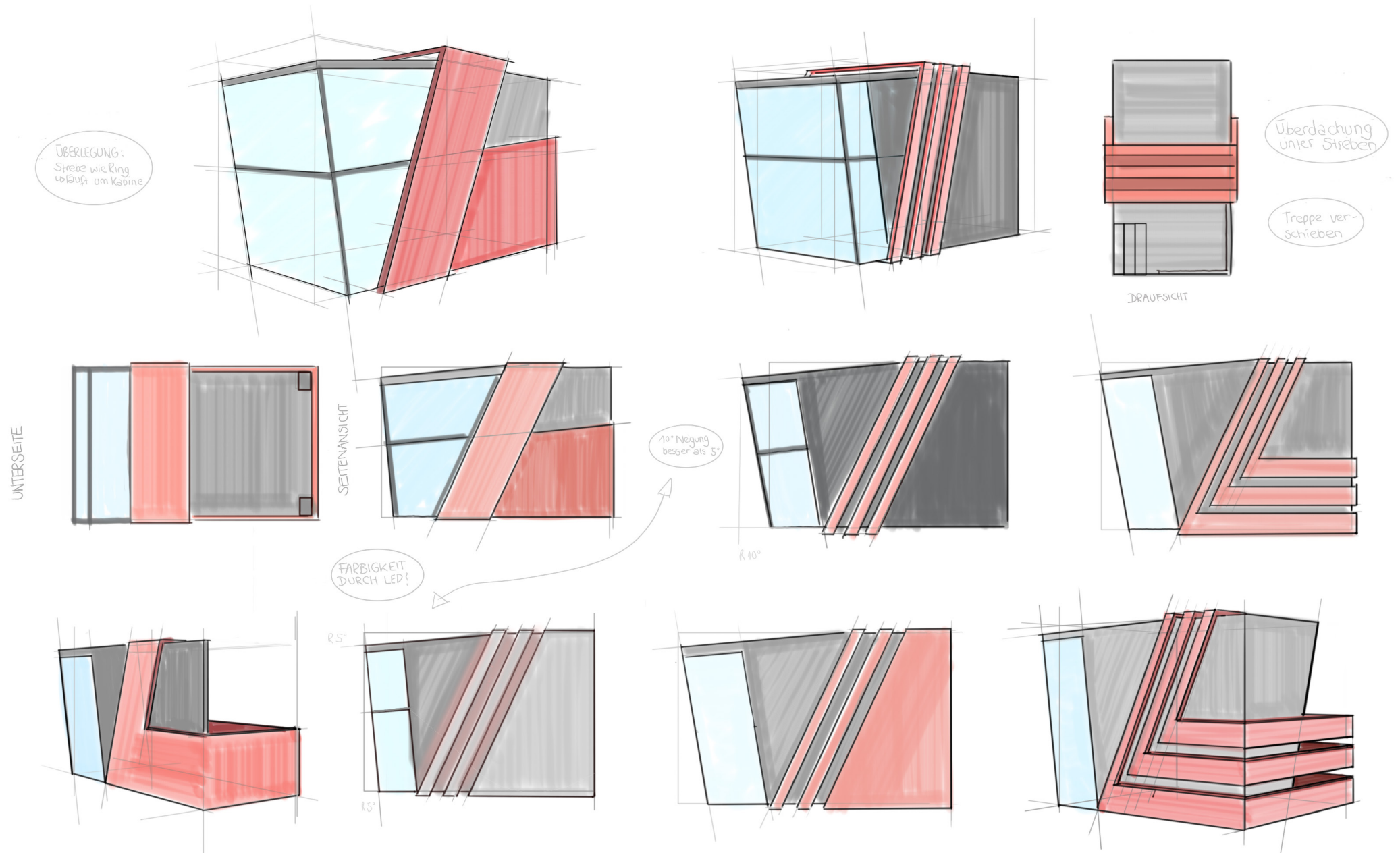

KABINE

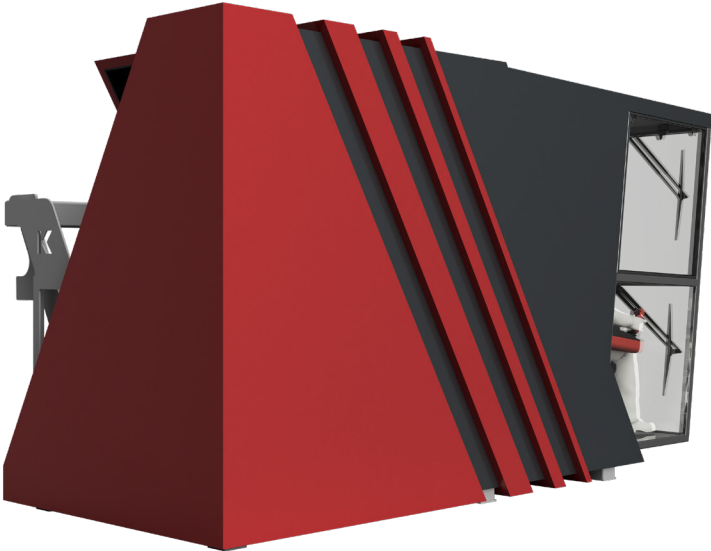
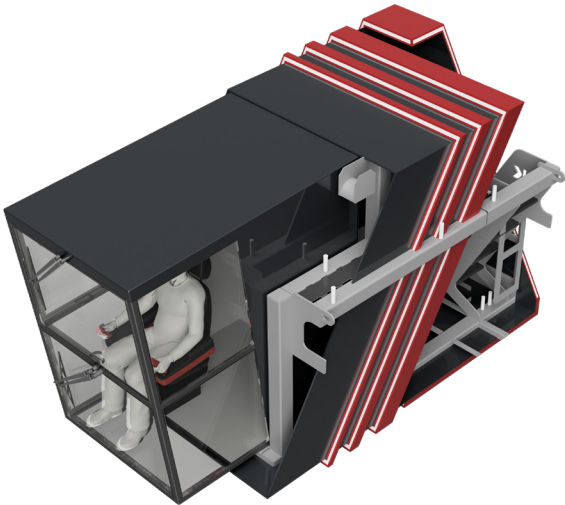
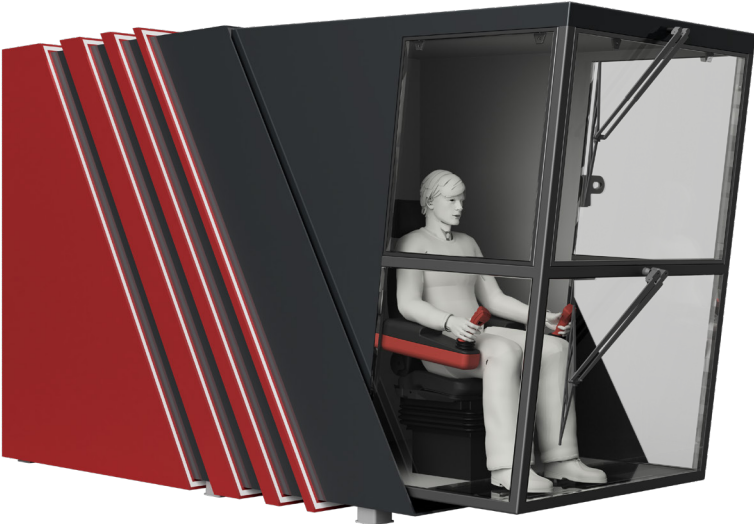
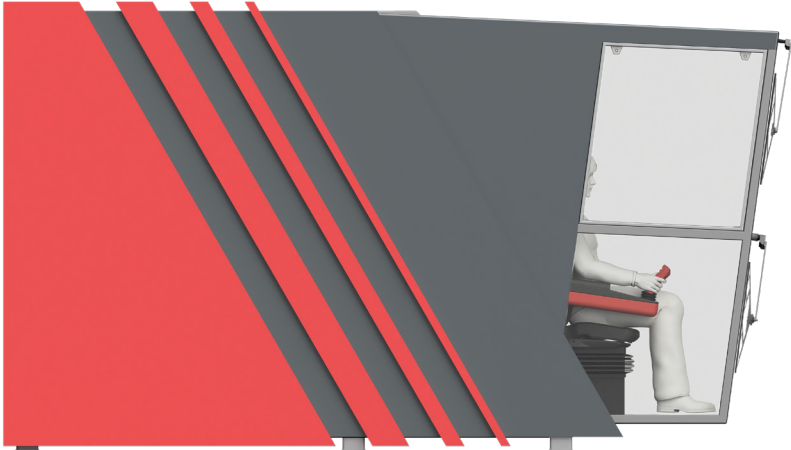

GEGENGEWICHT

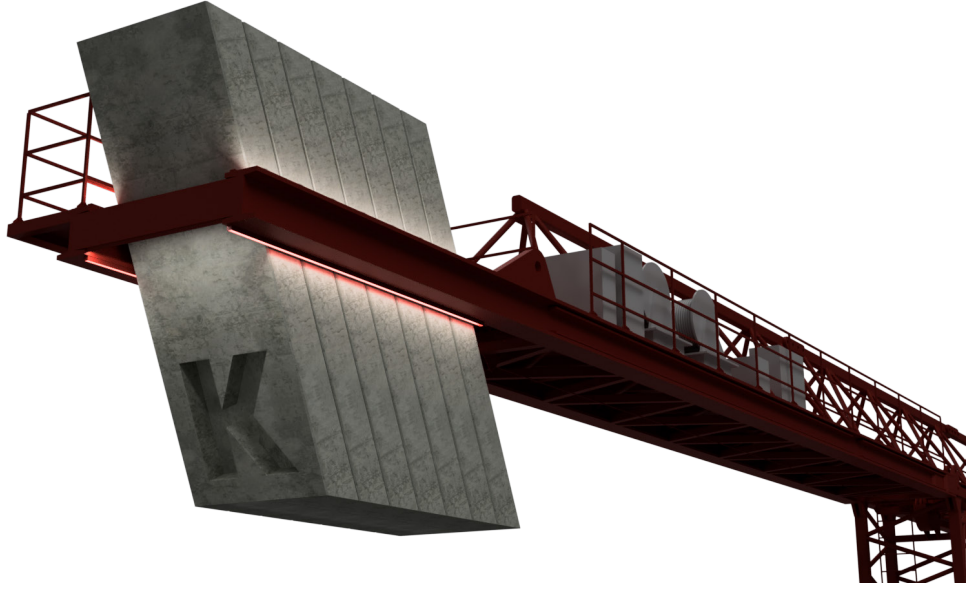
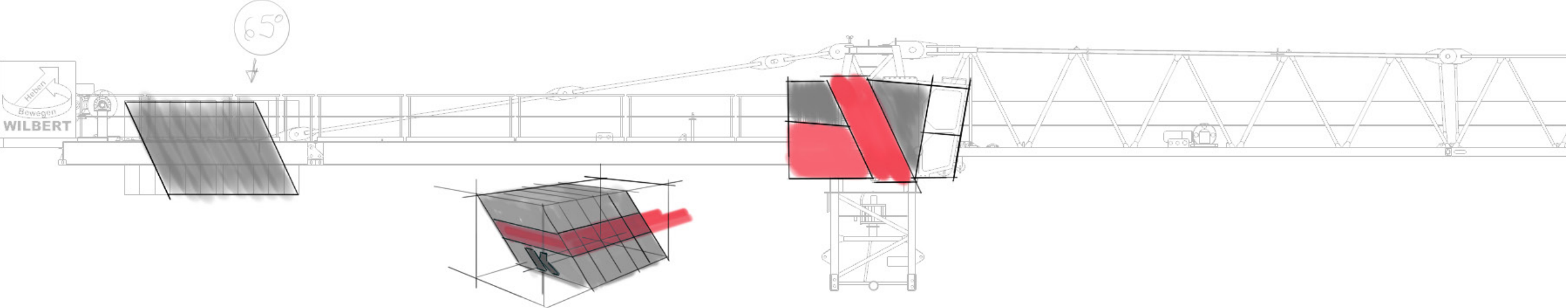

FUNDAMENT



1. Schritt

Scanne den QR-Code



2. Schritt

Weiterleitung zur Website von Kaufmann City View

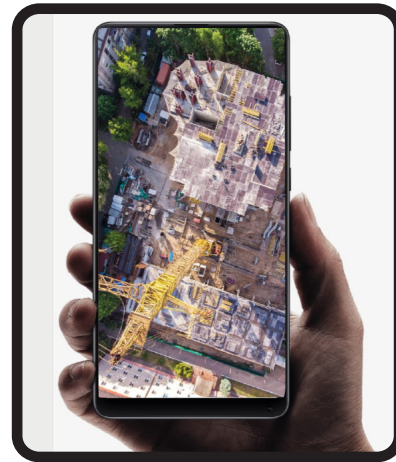

3. Schritt

Betrachte die Baustelle aus der Kranperspektive

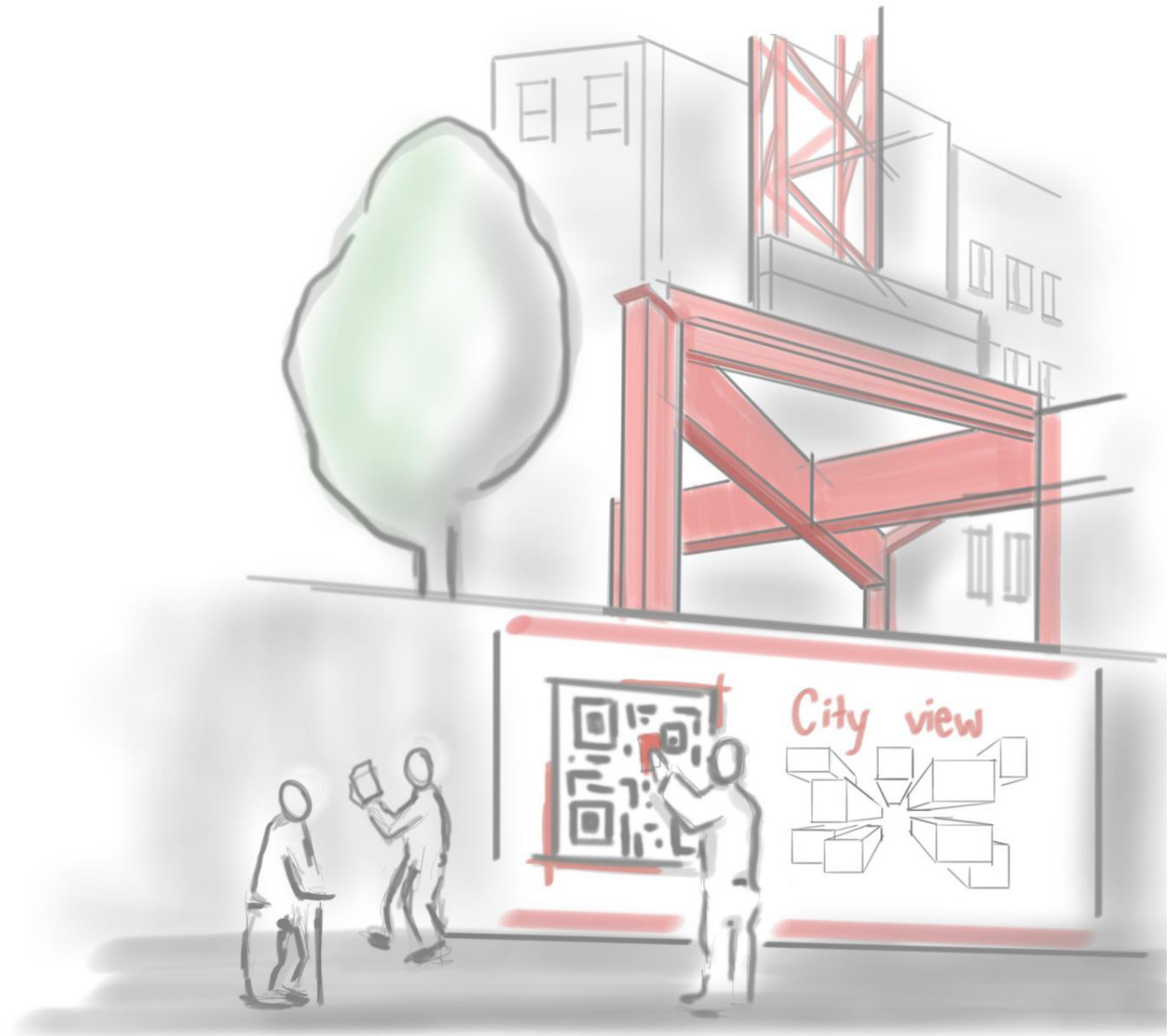

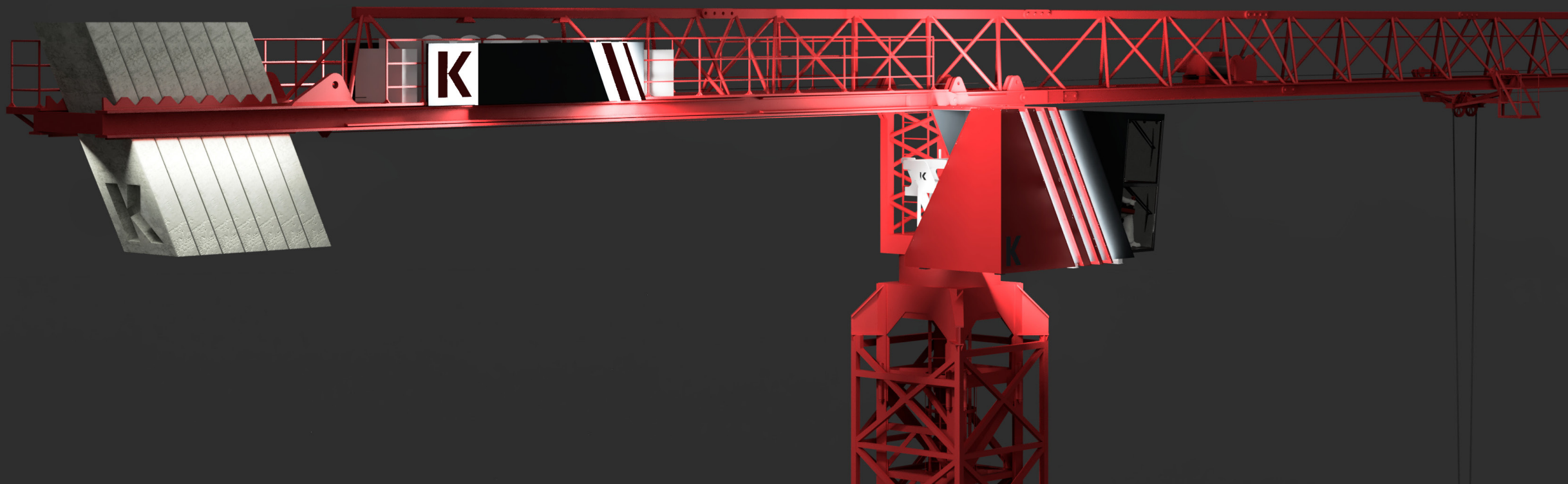



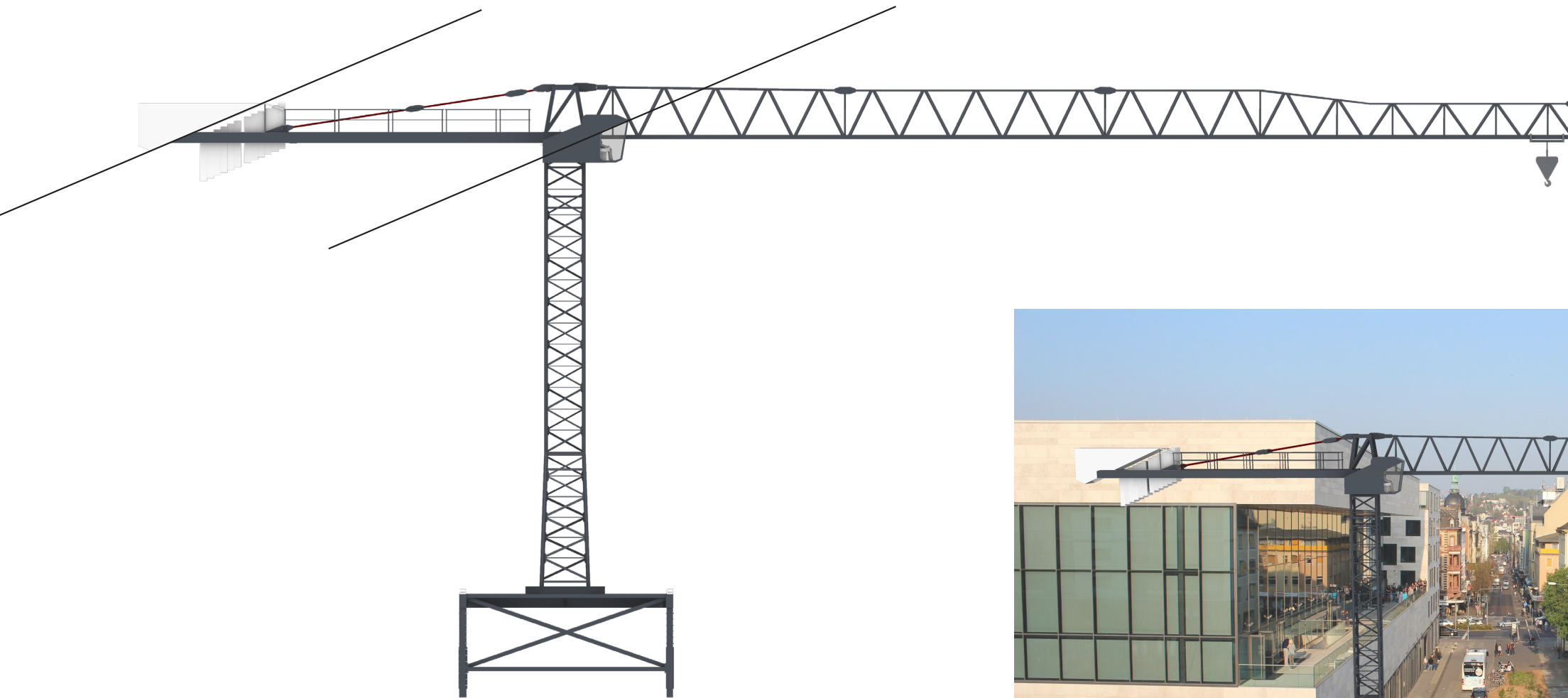

Krankonzept

Abrundungen

markanter Winkel

durchgehende Glasfront

Kabine

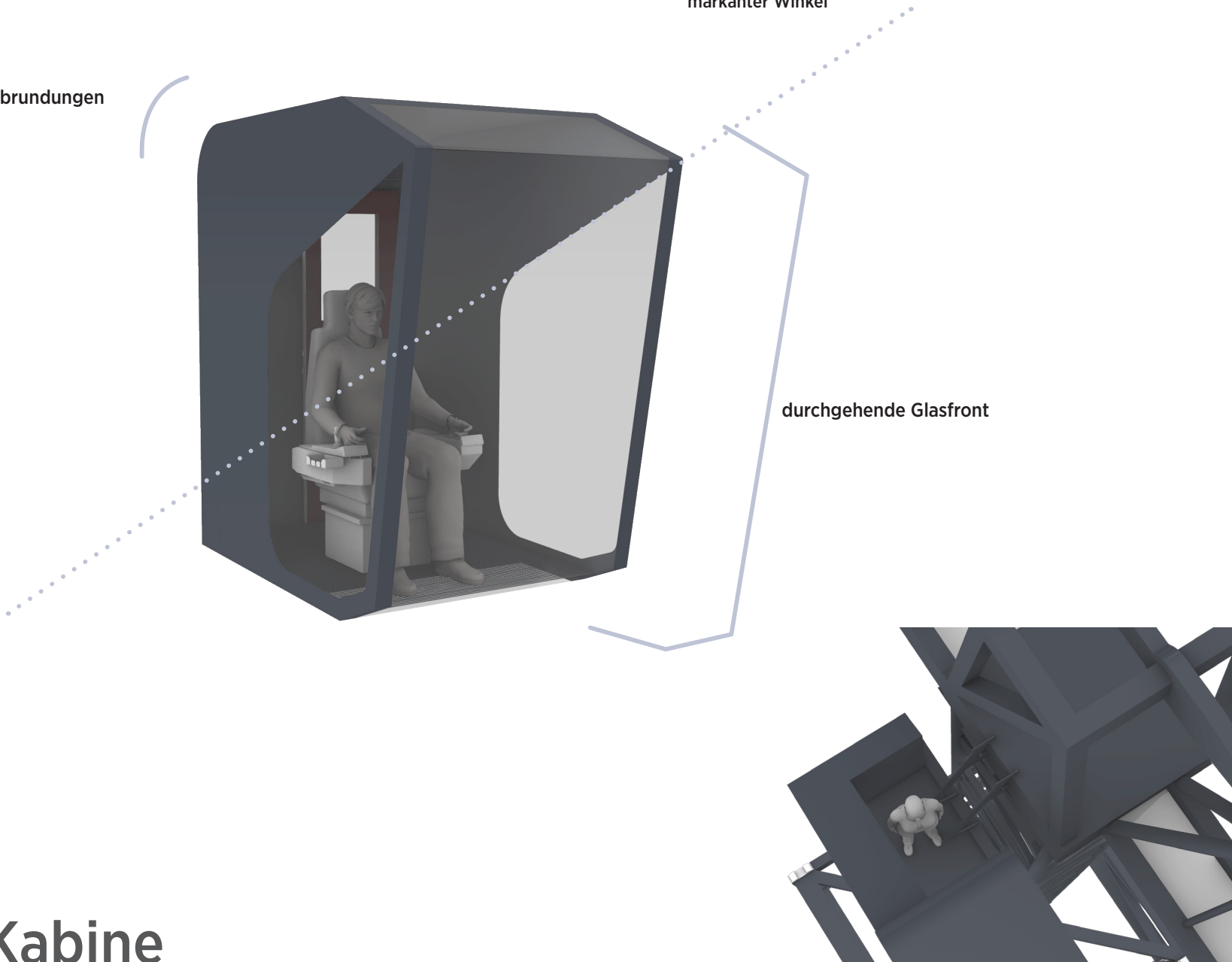

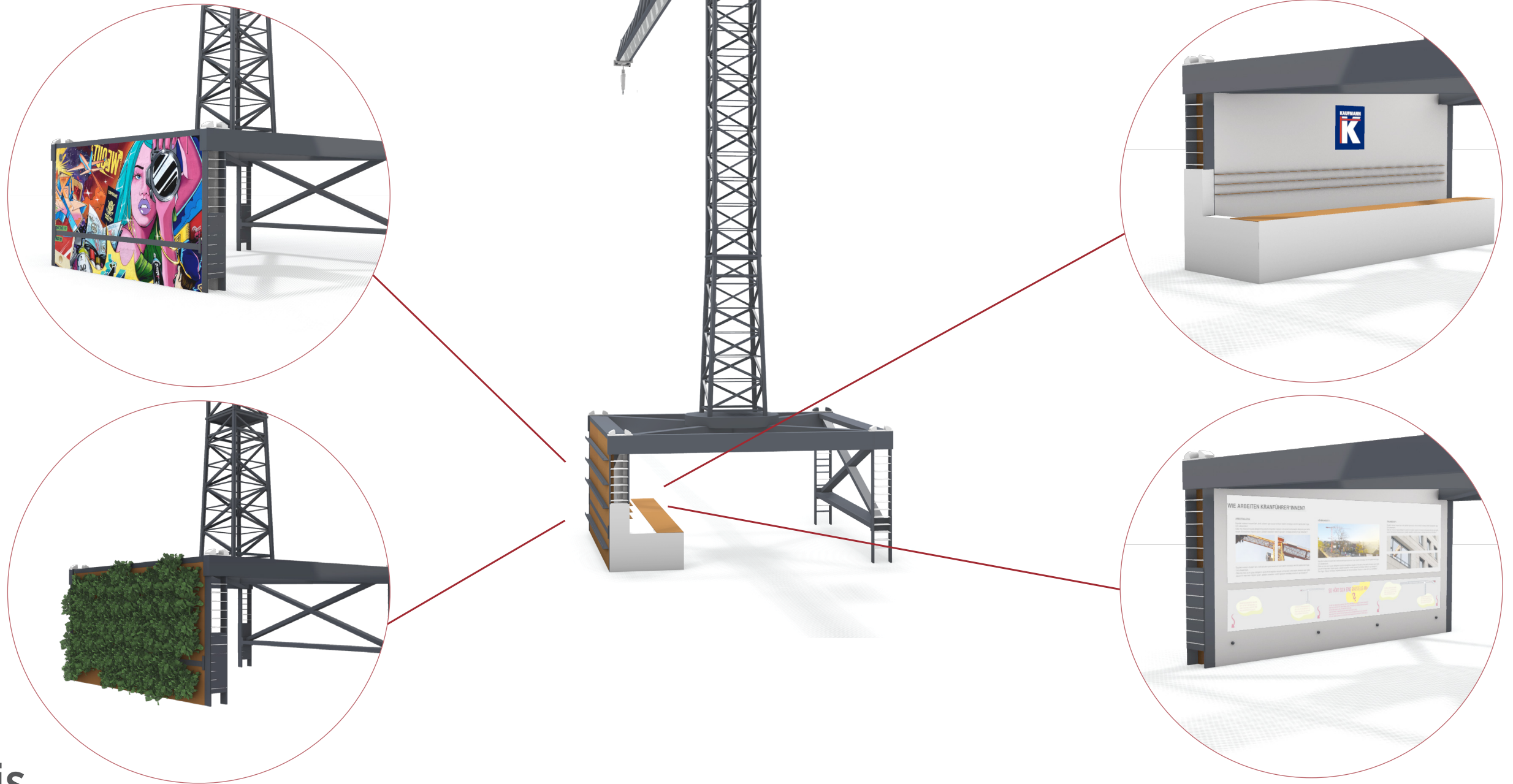

Basis

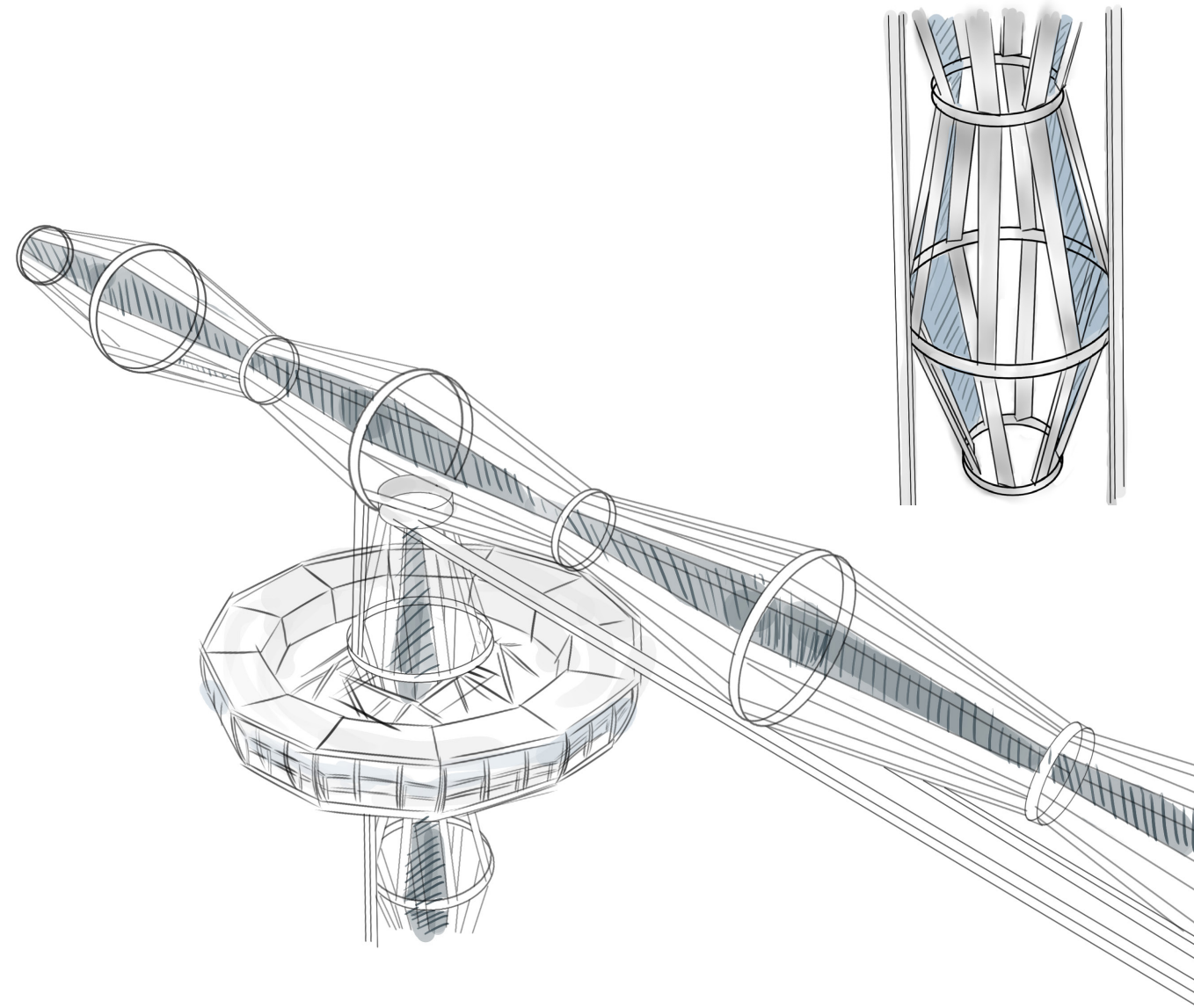

Zukunftsvision

IP7 | INTEGRIERTES PRODUKTDESIGN | DESIGNPROJEKT KRAN | QUYEN, TOBIAS, LINA, FRANZISKA

KRANKONZEPT STAND DER TECHNIK

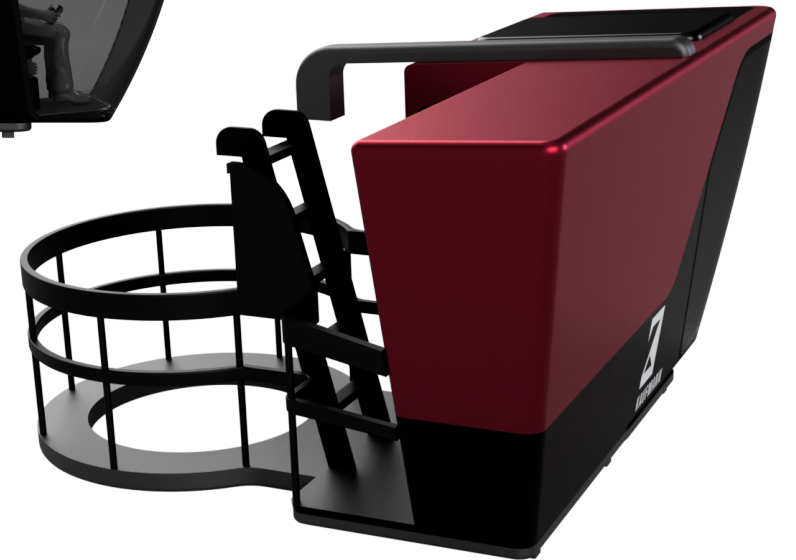
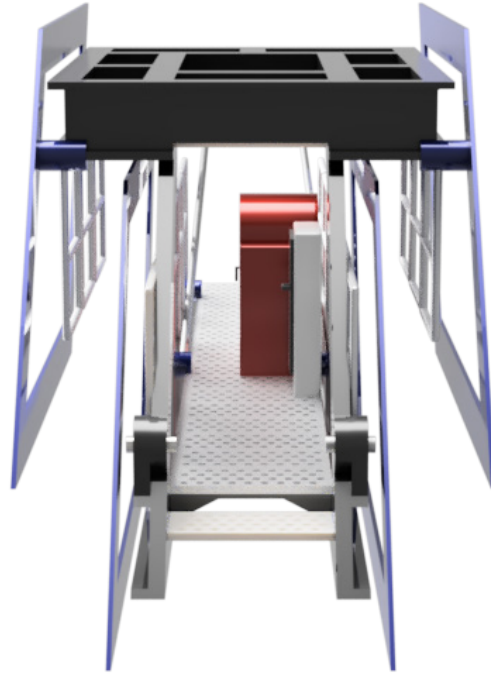
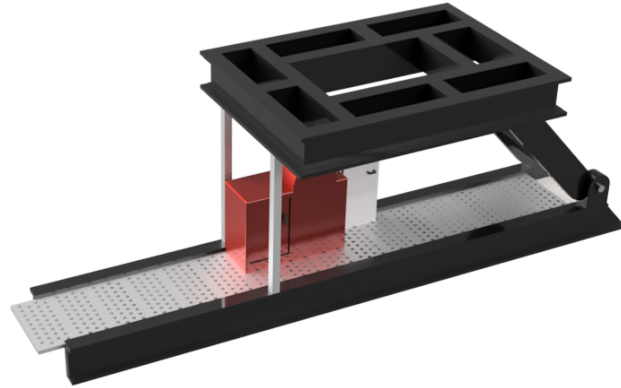
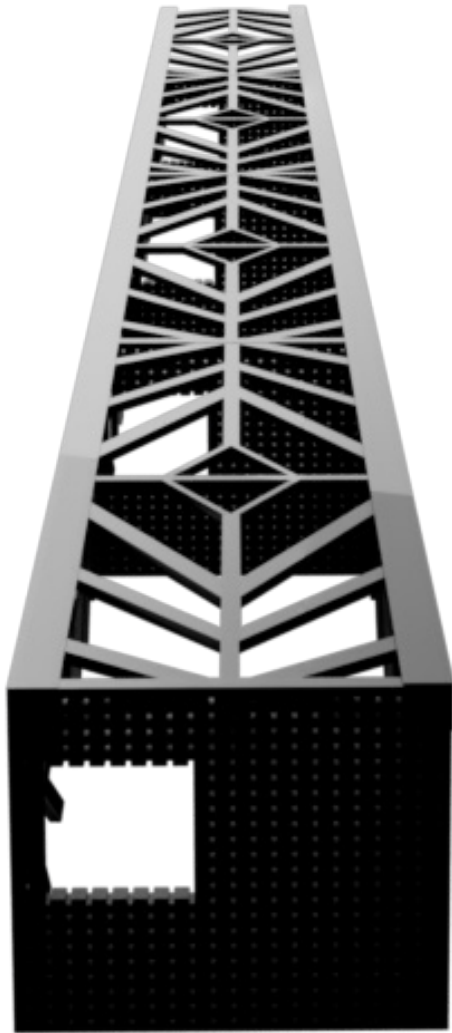

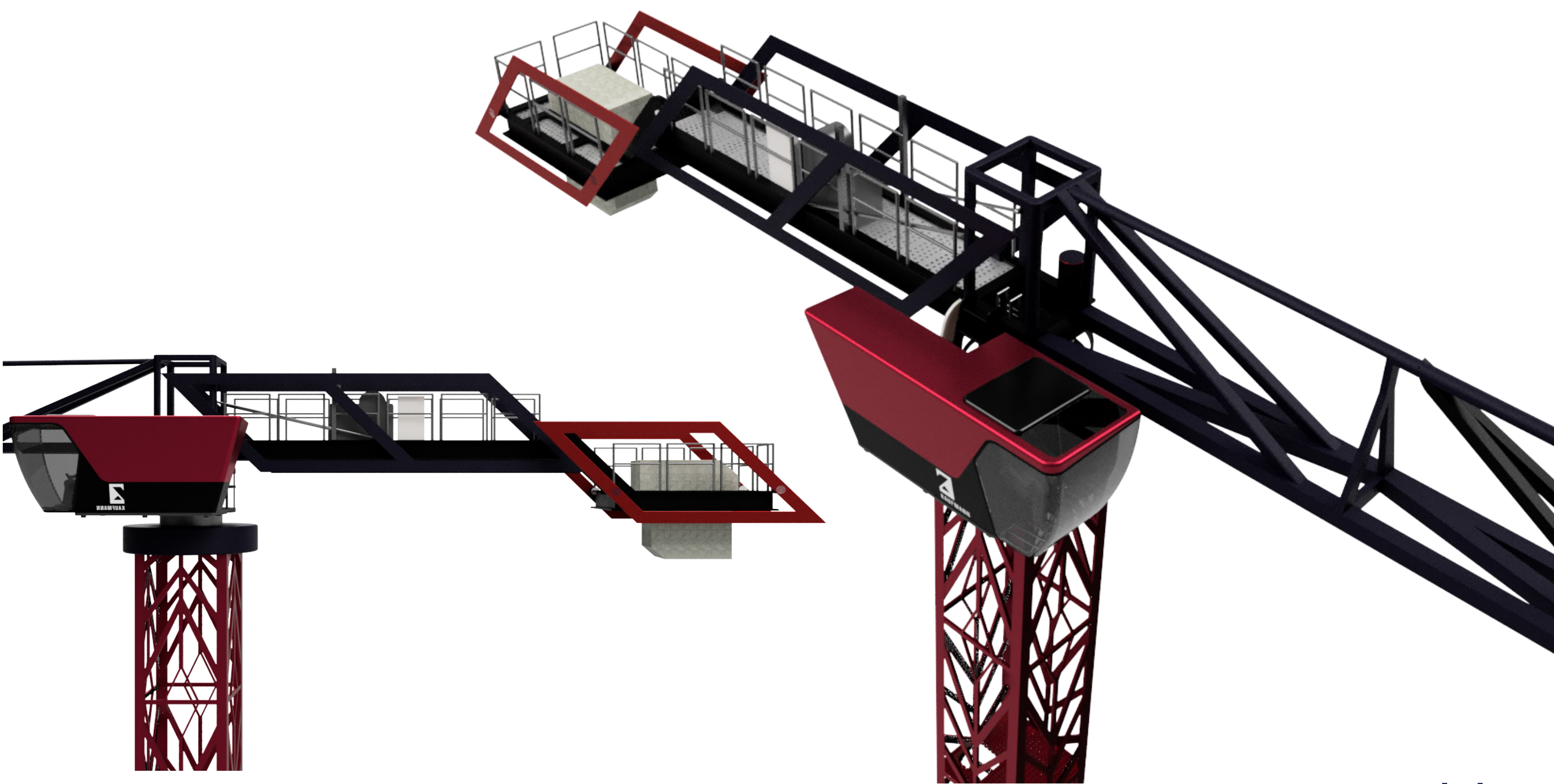

KRANKONZEPT VISION

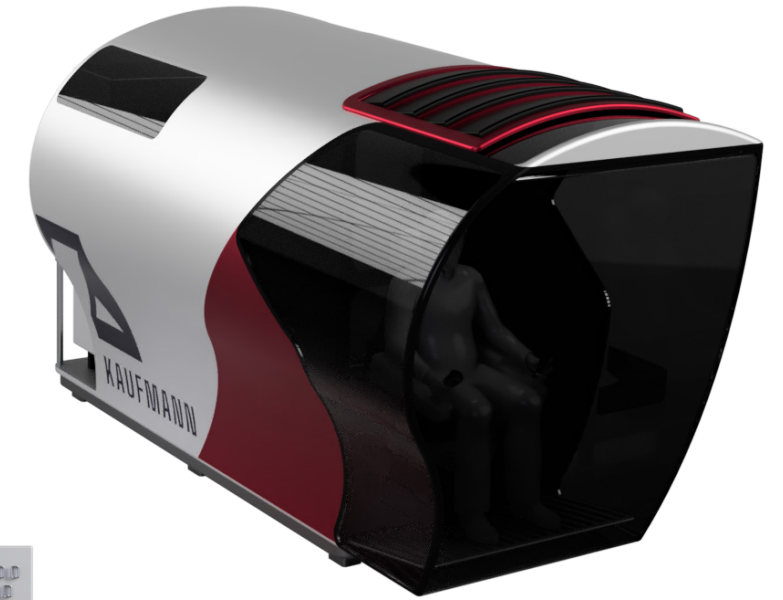
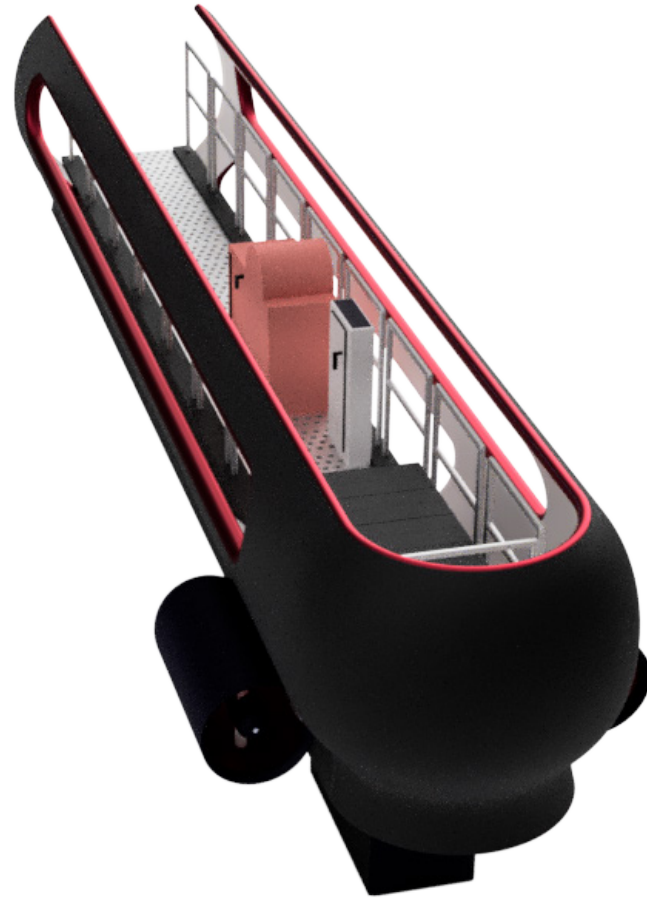
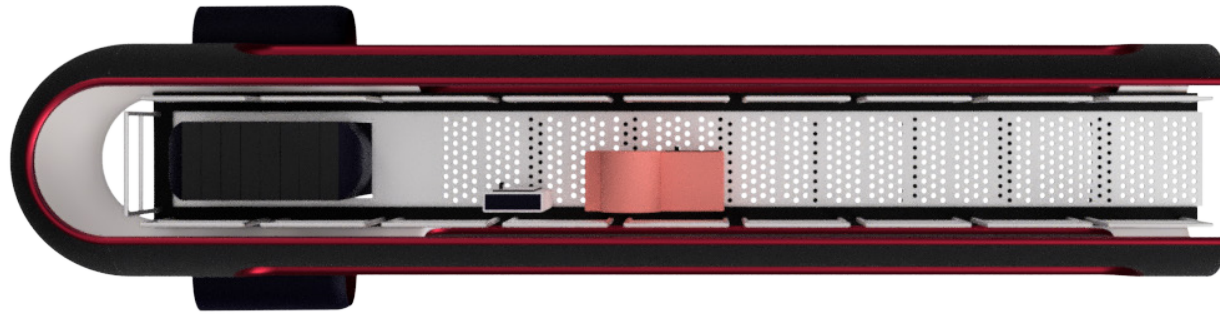

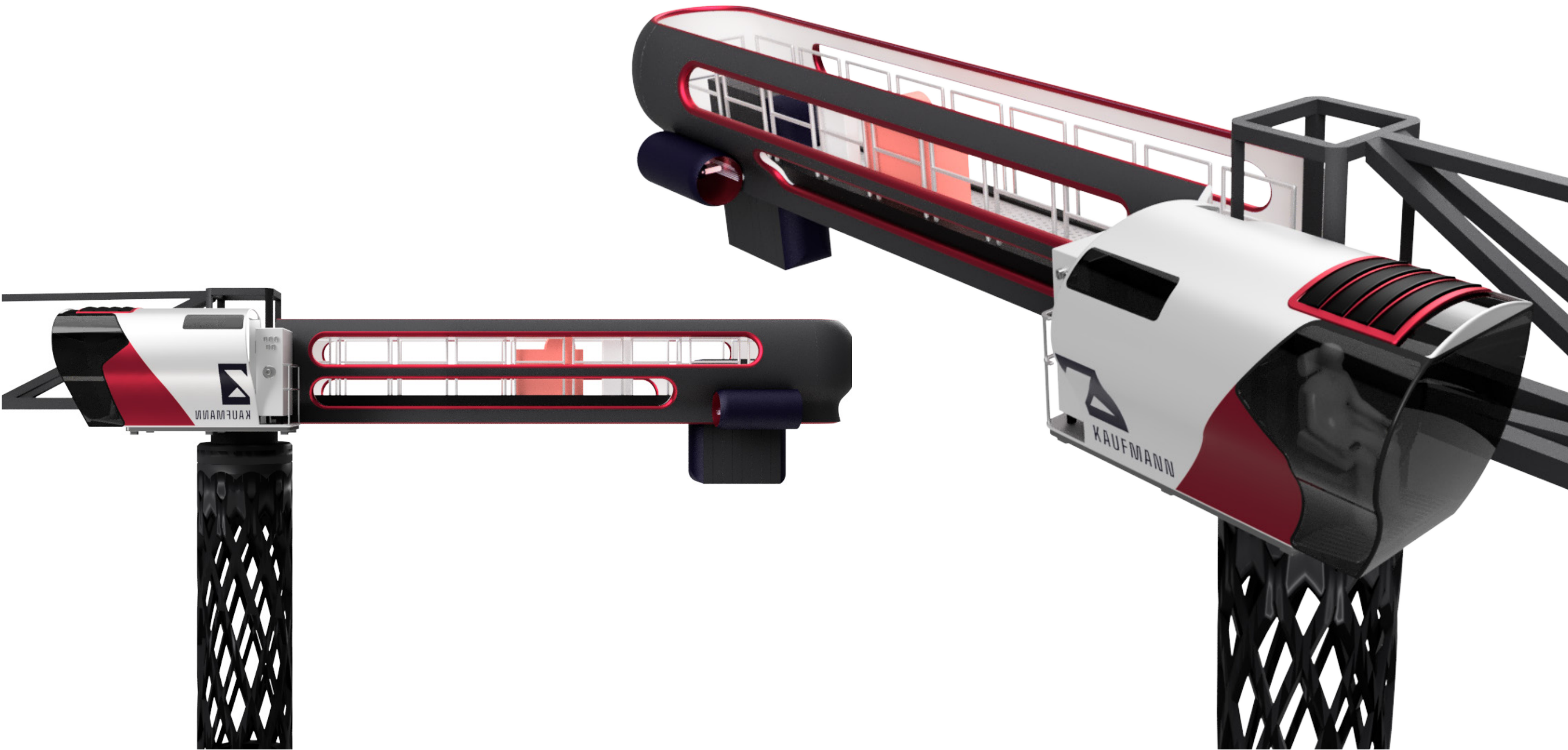

Kabinen Entwürfe

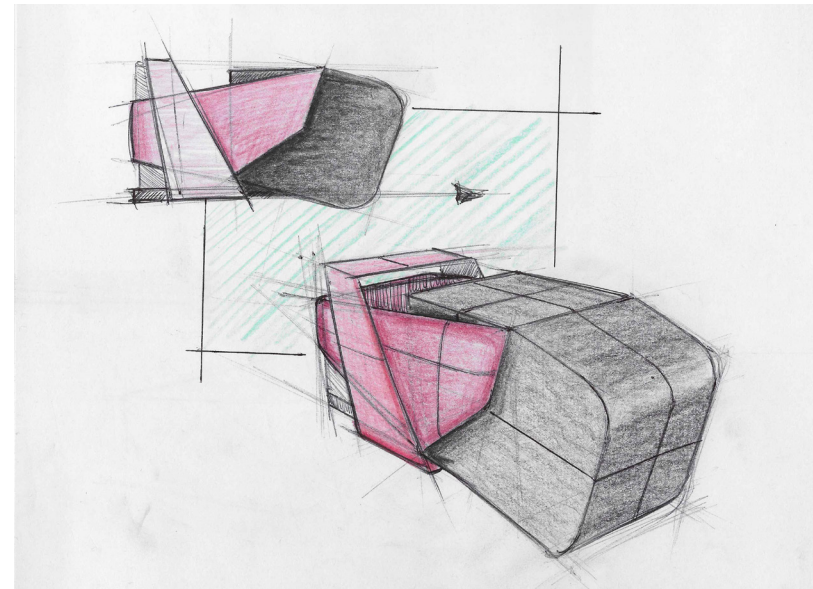
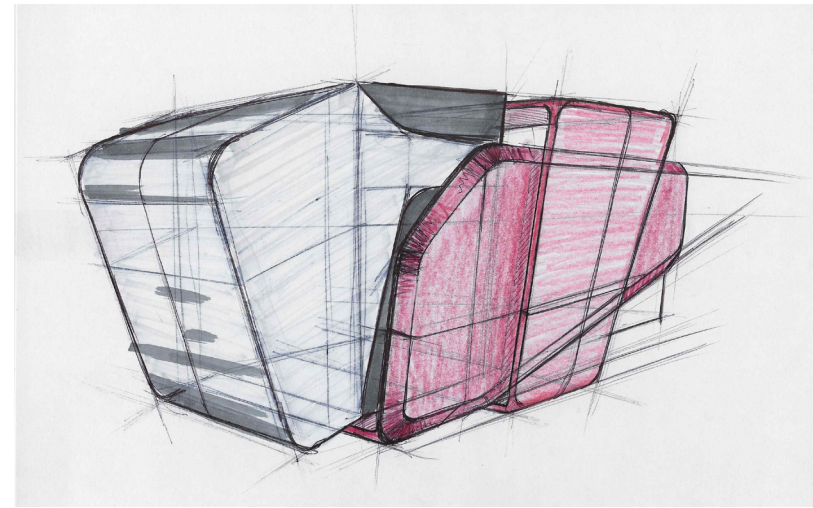
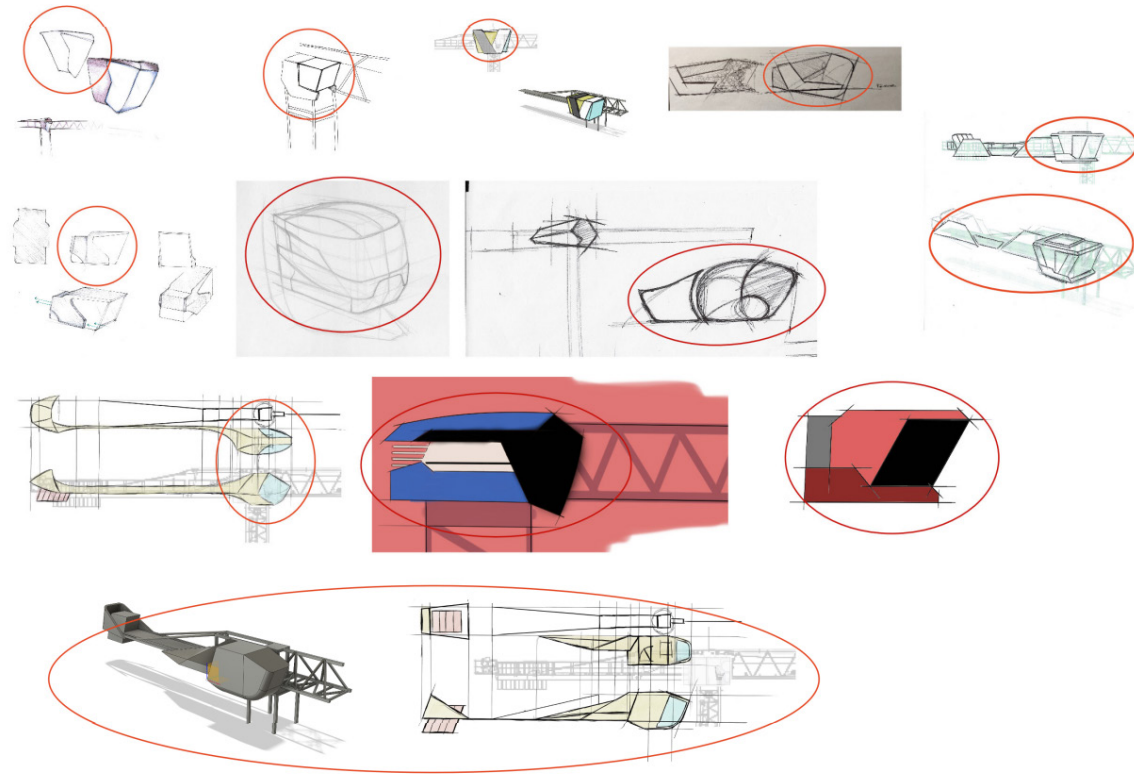

Kabinen Rendering

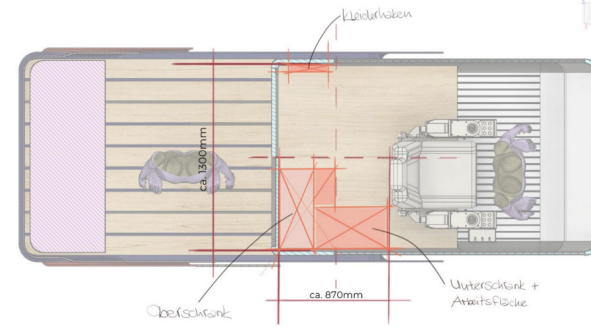
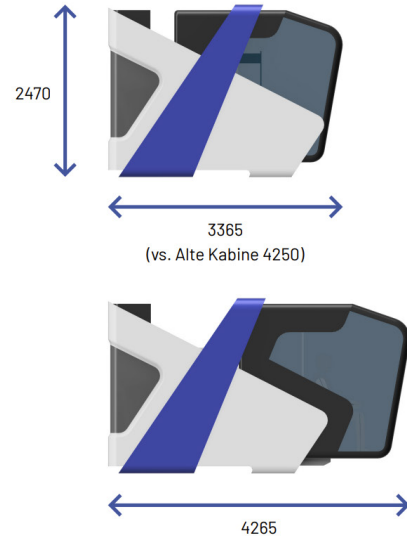
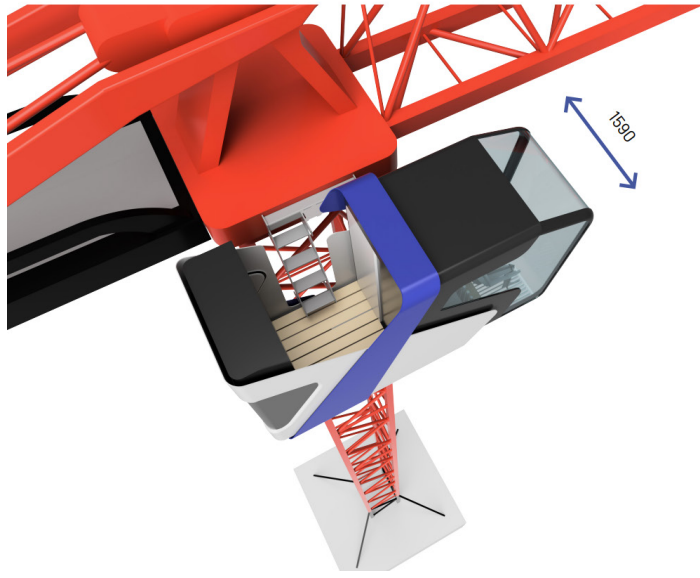

Gegenausleger | Endergebnis

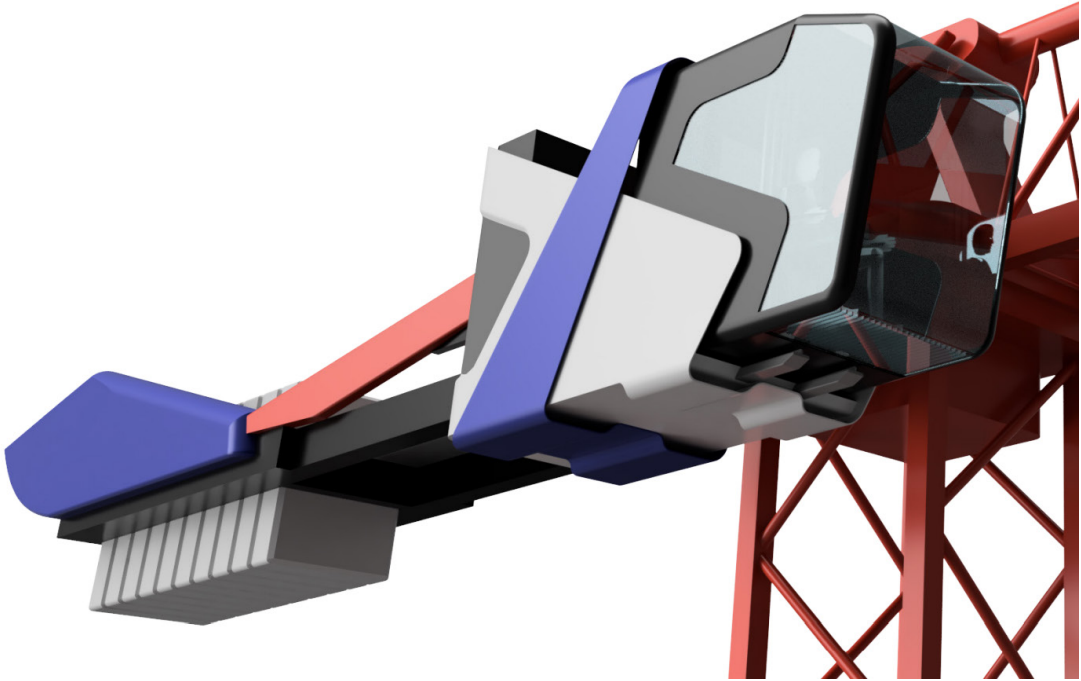
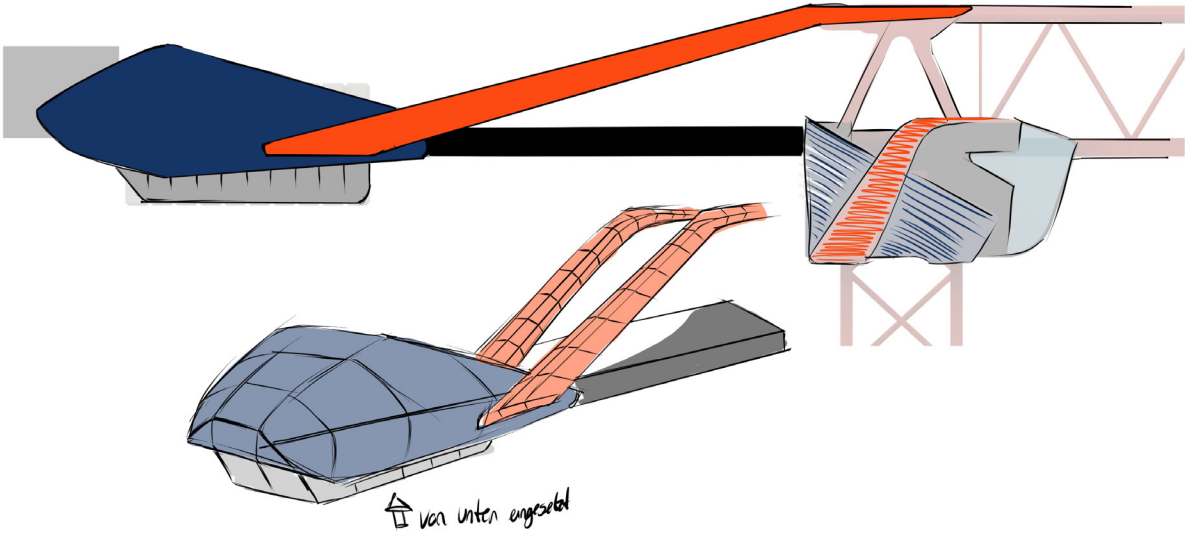

Vision Kabine

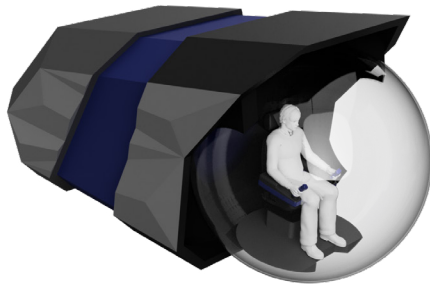
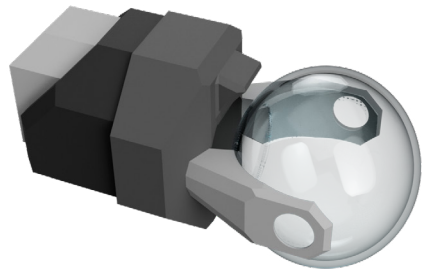
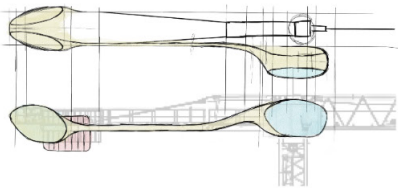
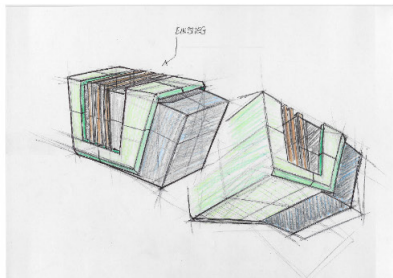
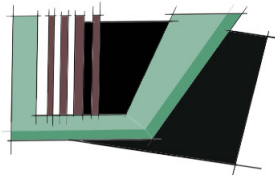
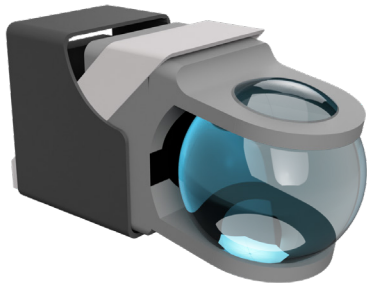
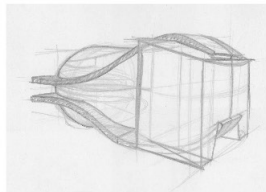
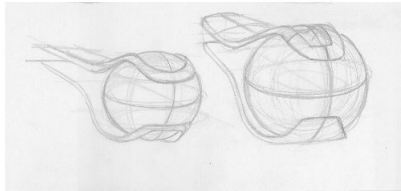
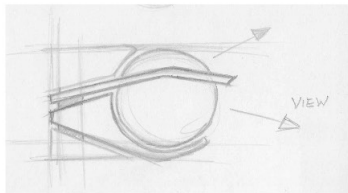

Vision Krankonzept

